

INFORMATION MANUAL

NATUZZI
ITALIA

INDEX

1.	THE FRAME	4
2.	THE PADDING	5
3.	THE FEET	7
4.	THE COVERING	8
4.1	TAKING CARE OF THE LEATHER COVERING	8
4.1.1	PROTECTA LEATHER	9
4.1.2	NATURAL LEATHER	10
4.2	TAKING CARE OF THE MICROFIBRE AND FABRIC COVERING	12
4.2.1	THE MICROFIBRE	13
4.2.2	THE FABRIC COVERING	15
5.	THE RELAX FUNCTION	16
5.1	ARMCHAIR AND SOFAS WITH MANUAL MECHANISM	16
5.1.1	RECLINING WITH DORSAL PRESSURE	16
5.1.2	RECLINING WITH EXTERNAL HANDLE	16
5.1.3	RECLINING WITH INTERNAL HANDLE	17
5.1.4	RECLINING WITH SLIDING FUNCTION	18
5.1.5	RECLINING WITH ARMREST AND HEADREST	19
5.1.6	ARMCHAIR WITH ROTATING FUNCTION	20
5.1.7	ARMCHAIR WITH ROCKING CHAIR FUNCTION	20
5.2	ARMCHAIRS AND SOFAS WITH ELECTRIC MECHANISM	21
5.2.1	RECLINING ELECTRIC MODEL WITHOUT HEADREST	22
5.2.2	RECLINING ELECTRIC MODEL WITH MANUAL OPENING OF HEADREST	23
5.2.3	RECLINING ELECTRIC MODEL WITH ELECTRIC OPENING OF HEADREST	24
5.2.4	MODEL WITH ELECTRIC SLIDING FUNCTION	25
5.3	ARMCHAIRS AND SOFAS WITH SOFT TOUCH ELECTRIC MECHANISM	26
5.3.1	MODEL WITH SOFT TOUCH ELECTRIC MECHANISM	26
5.3.2	MODEL WITH ELECTRIC SOFT TOUCH CHAISE LONGUE	27
6.	ARMCHAIRS AND SOFAS WITH AUDIO FUNCTIONS	28
6.1	ARMCHAIRS WITH AUDIO FUNCTIONS	28
6.2	SOFAS WITH AUDIO FUNCTIONS	29

7.	ARMCHAIRS AND SOFAS WITH ELECTRIC MASSAGE	30
8.	THE BED MODELS	33
8.1	DOUBLE FOLDING BEDSPRINGS	33
8.2	TRIPLE FOLDING BEDSPRINGS	34
8.3	TRANSFORMABLE SOFA BED	35
8.4	READY-BED SOFA	36
9.	MODELS WITH REMOVABLE COVERINGS	37
9.1	USE	37
9.2	WASHING METHODS	37
9.3	INSTRUCTIONS TO REMOVE THE SOFA COVERING	38
9.4	INSTRUCTIONS TO REPLACE THE SOFA COVERING	39
9.5	INSTRUCTIONS TO REMOVE AND REPLACE THE COVER FOR A SOFA OR BED WITH FIXED BACK AND FASTENED SEATING CUSHIONS	40
10.	SECTIONAL MODELS	41
10.1	INSTRUCTIONS FOR METAL DOWEL ASSEMBLY	41
10.2	INSTRUCTIONS FOR PLASTIC BRACKET ASSEMBLY	42
10.3	INSTRUCTIONS FOR UNIVERSAL TAB ASSEMBLY	44
10.4	INSTRUCTIONS FOR METAL BRACKET ASSEMBLY	46

1. THE FRAME

The strength of our sofas is guaranteed by a wooden structure designed to withstand the various stresses to which it is subjected during its working life. The materials used are selected both during the purchasing phase and when introduced to the production cycle and are tested repeatedly in the Natuzzi laboratory to measure their performance in every climatic condition and over time.

The wood, the main material used to produce the frame, does not originate from natural virgin forests, national parks, natural reserves or from protected areas and complies with the most demanding international standards regarding the chemical substances it contains.

The frame is designed and engineered by our technicians using sophisticated electronic techniques and is cut with numerical control machines. All the new models are subject to further testing in the laboratory in compliance with the major international standards before being manufactured.

High resistance belts, patented for furniture applications are mounted on the frame, these contribute to achieving the optimum comfort together with the padding.

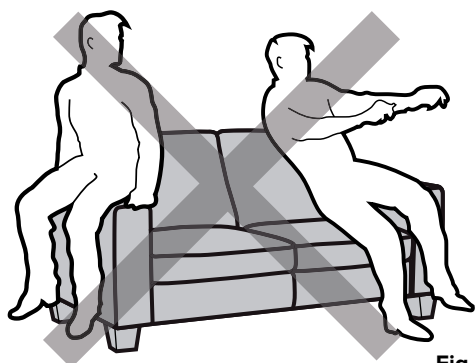

Fig. 1

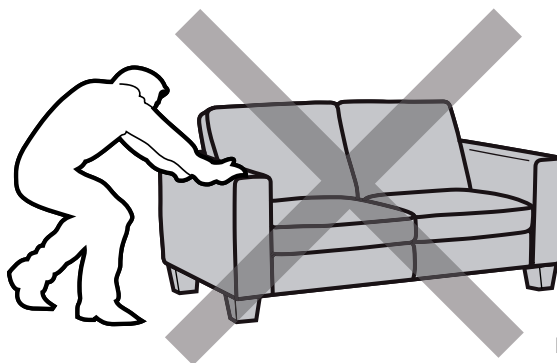

Fig. 2

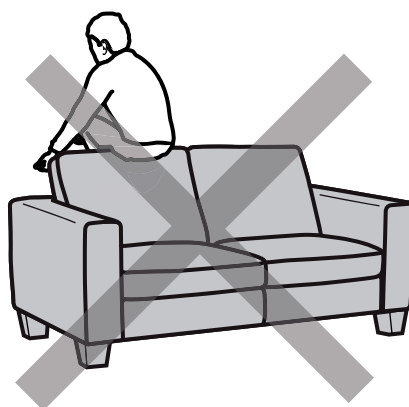

Fig. 3

WARNING

The frame inside your sofa will always remain intact and perfect over time, provided you comply with the following recommendations:

- Avoid jumping on the sofa and do not throw yourself violently onto the (Fig. 1)
- Do not sit on the arms and/or the back. (Fig. 1 Fig. 3)
- Do not drag the sofa over rough surfaces (carpets, wall-to-wall carpeting, etc.) and if the sofa has to be moved, it must be lifted and not pushed, even when on smooth surfaces. (Fig. 2)
- Do not pull the sofa by the arm to avoid breaking the stitching.

2. THE PADDING

We use three types of padding, depending on the shape and the style of each model:

Polyurethane, Polyester fibre down and Goose feathers.

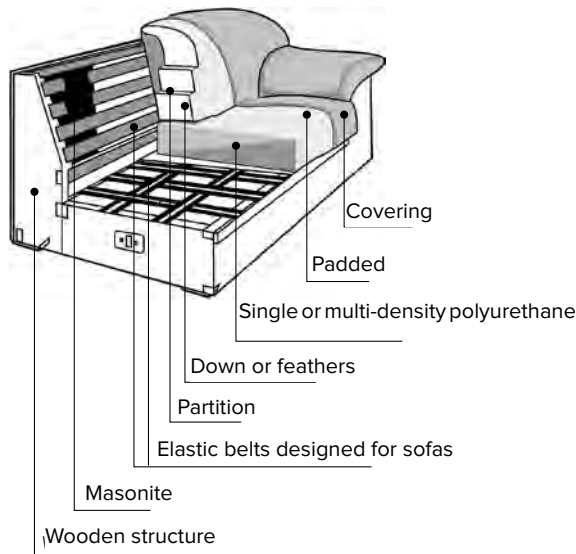

Our technicians study the ideal technical characteristics of the polyurethane for each model, in terms of density and hardness. Each type of polyurethane, fully respecting the environment, is tested in our laboratory before being produced to check the level of comfort over time.

The fibre fillings are very thin polyester filaments that are able to ensure a high degree of softness after being processed in a special way. These fibre fillings, selected to pad the seating, back and armrests, are used to provide a level of comfort that has even greater softness, particularly in the points that come into contact with the more delicate parts of the body.

Natural goose feather padding is used for the same purpose, which has outstanding quality and a high degree of softness after selection and sterilisation.

USE AND MAINTENANCE

The Natuzzi padding material does not require any specific type of maintenance except for the kind associated with the normal care of the sofa. In particular, if you purchase sofas that have a fibre filling or down padding, it will be necessary to model them delicately to ensure they return to their initial appearance, which will have altered during transportation. We recommend that you repeat this operation every day or after every use.

In fact, the sofa is subjected to a long journey before reaching your home, which could temporarily affect the initial aesthetic quality.

To this end, you will find an illustration sheet inside the envelope containing the feet attached to the product, which will provide you with the main recommendations to return your sofa to its original excellent look.

WARNING

- During the first 3 months of life polyurethane foam padding tends to become softer and then finally stabilises itself. This process is absolutely normal, in fact, pressure is applied on the seating that breaks the micro-cells that comprise the polyurethane when a person sits down for the first time. This breakdown, which is absolutely natural for this type of material, produces a slight softening effect.
- Again when the sofa is purchased, for the same reason mentioned above, it is absolutely normal that the softness of a seat/back, an end seat or a pouf, padded using polyurethane foam, is found to be different from the one adjacent, depending on the specific use. This characteristic will disappear after the first 3 months of proper use.
- Light creases may form on the covering following the above mentioned natural settling of the padding. These creases are to be considered absolutely normal and depend on the settling of the leather during the initial 3 months of normal use.

BEFORE modelling

AFTER modelling



Advice to restore an excellent appearance to your sofa:

Beat the backrest cushions with both hands smoothing the cushion from the inside to the outside **Fig. 1** Beat the backrest cushion with one hand, holding it with the other at the rear. **Fig. 2**



Fig. 1



Fig. 2

Pull the end of the cushion with one hand and beat it with the other **Fig. 3** After the back, move to the two armrests; beat them evenly moving from the inside towards the outside **Fig. 4**



Fig. 3

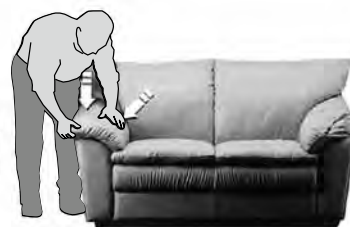

Fig. 4

After use, stretch out the covering as shown in the photos. **Fig. 5 Fig. 6**



Fig. 5

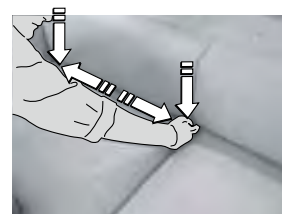

Fig. 6

Avoid the concentration of folds at the centre of the seats. **Fig. 7**

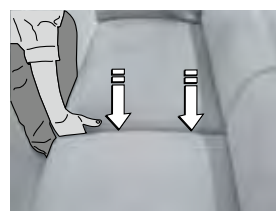

Fig. 7

3. THE FEET

The feet represent an integral part of the sofa. They are accurately designed and produced using specific materials to ensure that the best aesthetic result is achieved, regardless of this there may often be normal differences in tone or natural veining.

For some models, the feet must be mounted at the destination.

Read the instructions detailed in the attached document before mounting the feet. Avoid removing the sofa packing using pointed or sharp objects that may damage the covering. Spread the cellophane sheet on the floor, lower the sofa so that the back rests against the floor and proceed as follows:

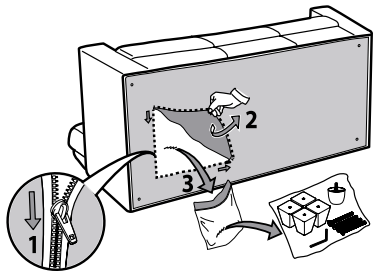

Fig. 1

- open the zip of the pocket inserted in the lower part of the structure and remove the envelope containing the feet. **Fig. 1**

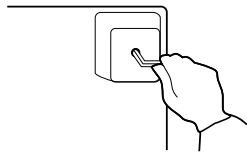

Fig. 2

- tighten the feet firmly. **Fig. 2**

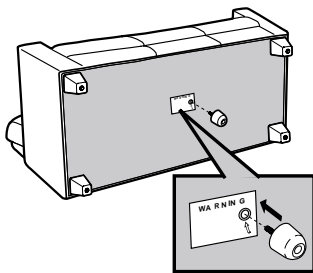

Fig. 3

- mount the central feet, if provided, in the positions shown by the labels that you will find on the sofa's base. **Failure to mount these feet could compromise the resistance of the wooden structure.** **Fig. 3**

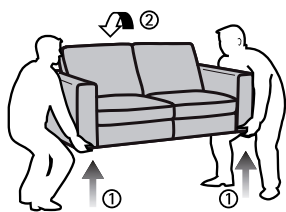

Fig. 4

- The sofa must be lifted (1) and turned (2) to return it to an upright position, but avoid using the feet as a lever to prevent breaking them **Fig. 4 Fig. 5**

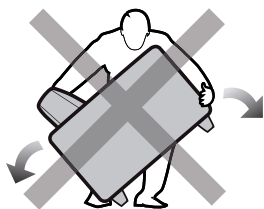

Fig. 5

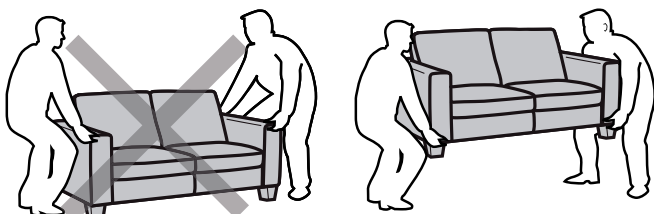

Fig. 6 Fig. 7

- avoid moving the sofa by dragging or lifting by the armrests: the correct way to move the sofa is by lifting it from the base. **Fig. 6 Fig. 7**

4. THE COVERING

The following covering materials may be used on our sofas:

Leather,
Microfibre,
Fabric

There may be more stitches when the sofa is leather covered (**Fig. A**), compared to the same model with a fabric or microfiber covering. (**Fig. B**)

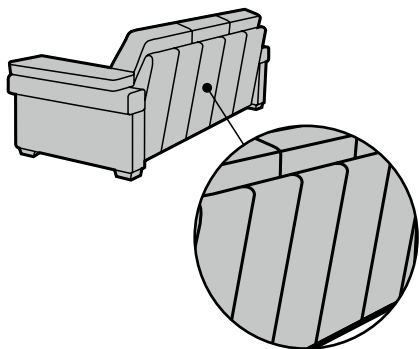

Fig. A

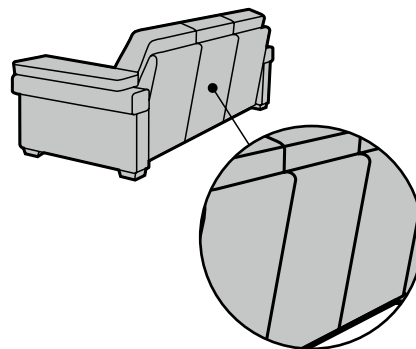

Fig. B

Furthermore, depending on the structure of the fabric, the type of stitching may differ, or in some cases, there may be no border.

4.1 TAKING CARE OF THE LEATHER COVERING

We recommend you read the instructions that follow carefully if you have purchased a leather sofa, paying particular attention to the description of the leather family that you have selected ('Protecta' or 'Natural') and the advice for the care, maintenance and relative warnings for this particular covering.

Natural leather is a noble and resistant material, which becomes more valuable with time. Leather offers an ideal level of comfort both during the hot months and the cold months thanks to its properties of transpiration and flexibility; moreover, leather transmits a pleasant feeling of a warm embrace by adhering perfectly to the shape of the body. Each hide has its own story that can be read by the natural signs impressed on the surface, such as scars, lines, insect bites, stretch marks, veining, differences in grain and colour.

This is the reason our craftsmen check the hides one by one and process them in a different way to enhance their natural characteristics, obtaining superior hides suited to different domestic uses.

4.1.1 PROTECTA LEATHER

Protecta leather is the result of production processes that confer protection and high performance to the leather. A thin finishing layer protects the leather from stains, without altering its original characteristics. The Protecta leather products combine the advantages of natural qualities and softness with good resistance to wear and changes of colour. The presence of distinctive marks that tell the story of the animal's life, such as healed scars, grain differences, wrinkles, veining, differences in colour shades and any other sign that nature has left on these hides, prove they are absolutely genuine and bears witness to their great worth.

Cleaning the Protecta leather collection

- Periodically dust using a clean, dry and non-abrasive white cloth.
- For stains caused by soft drinks, coffee, tea, milk, chocolate, oil, fat, cosmetics, foundation cream: remove the stain rapidly from the surface, by dabbing with absorbent cloth or paper. Then, delicately rub working from the outside towards the centre of the stain using a cloth soaked in a water and mild white soap solution. Do not soak the leather surface, and dry the surface immediately using a clean cloth.

Do not dry the leather in direct sunlight or with a hair dryer.

WARNING

- Avoid exposing the sofa to direct sunlight or to powerful lamps to ensure the colour of the covering remains bright.
- The above listed causes, as well as the use of unapproved detergent substances, may irreparably damage the leather covering, causing cracks and changes in colour.
- If you purchase a new sofa, with a covering that is an identical article and/or is of the same colour as the sofa that you already own, it is possible that you may note slight differences in shades of colour between the two, because of the unique personality of each hide.

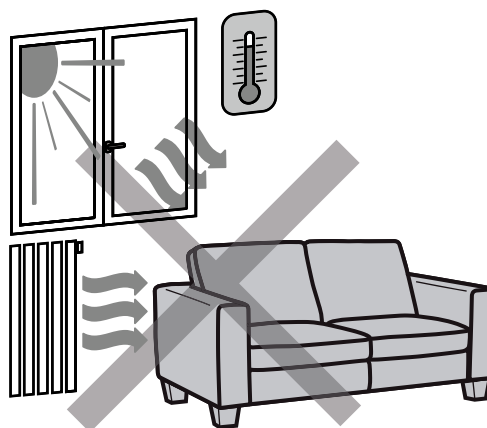

4.1.2 NATURAL LEATHER

The Natural leather products are processed without changing the original characteristics of the hides. The presence of healed scars, differences in grain, wrinkles, veining, differences in colour shades and any trace that nature has left on these hides, is proof that they are absolutely genuine and bears witness to their great worth.

Cleaning the Natural leather collection

- Periodically dust using a clean, dry and non-abrasive white cloth.
- For dry dirt: brush delicately using a brush with soft bristles or use a vacuum cleaner at the medium suction power setting, using the specific accessory supplied with the cleaner and taking care to avoid rubbing the accessory directly against the covering.
- For stains caused by substances soluble in water (soft drinks, coffee, tea, milk, jam): rapidly remove the liquid from the surface using a white, non-abrasive cloth (or absorbent paper). Then rub delicately working from the outside of the stain towards the centre, using a clean cloth soaked in water. Dry immediately with a clean cloth. Do not soak the leather surface, and dry immediately using a dry cloth. Do not dry the leather in direct sunlight or with a hair dryer.
- For stains caused by greasy substances (oil, ketchup, mayonnaise, chocolate): remove the substance delicately from the surface using absorbent paper, taking care not exert pressure to prevent the dirt from entering the pores of the leather. Use a clean cloth, soaked in a very dilute solution of neutral soap, rubbing delicately working from the outside towards the centre of the stain.
- Dry immediately with a clean cloth. Only use water and colourless, mild soap.

Cleaning the Natural Nabuk leather collection

The Natural Nabuk leather products also belong to the family of Natural products, they therefore have all the natural characteristics described previously. The “nabuk effect” is the result of a very light polishing, adopted to give the leather a velvet effect referred to as nabuk.

- These leather products can be cleaned using the same procedures described for the Natural leather products (see to the side).
- Rub very delicately using thin abrasive paper after the leather has been cleaned and dried, to restore the Nabuk effect.

WARNING

- Position the sofa at least 50 cm. from sources of heat such as heaters or radiators.
- Avoid exposing the sofa to direct sunlight or to powerful lamps to ensure the colour of the covering remains bright.
- The above listed causes, as well as the use of unapproved detergent substances, may irreparably damage the leather covering, causing cracks and changes in colour.
- If you purchase a new sofa, with a covering that is an identical article and/or is of the same colour as the sofa that you already own, it is possible that you may note slight differences in shades of colour between the two, because of the unique personality of each hide.

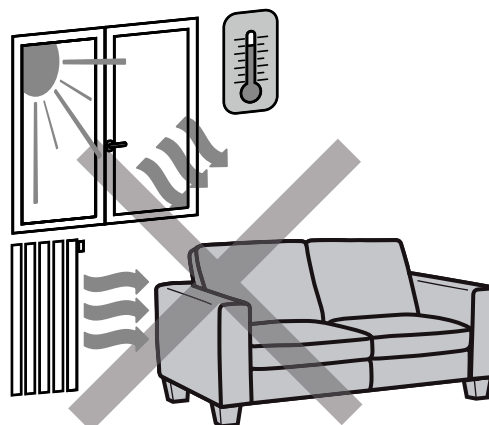

A number of natural characteristics that you will find on your 'Protecta' or 'Natural' leather covered sofa are listed below:



Low grain



Open scar



Closed scar



Grain difference



Insect bites



Wrinkle



Veining



Differences in shade

4.2 TAKING CARE OF THE MICROFIBRE AND FABRIC COVERING

We select the best coverings to cover our sofas, are fabrics are produced by the most important suppliers in the world, so they represent the ideal balance between quality and Italian style and are able to combine softness and practicality. All the articles are subjected to demanding quality tests such as the Martindale test, by which it is possible to determine their resistance to wear and tear. If you have purchased a sofa with a fabric or a microfibre covering we ask that you read the following instructions, focusing in particular on the recommendations concerning the care and maintenance of your category of covering (cleaning code A and C) **Fig. A**.

You will also be able to find the latter information on the label under the seat cushions if the covering is removable or under the sofa, if the covering is fixed.

Symbols to follow to properly clean the covering:



Do not wash in water



Wash using water (Max 30°C)



Wash using water (Max 40°C)



Dry clean using perchloroethylene
(delicate articles setting on the washing machine programme)



Dry clean using perchloroethylene



Dry clean using Fluorocarbon



Iron at a temperature not exceeding 100°C
Avoid using steam



Iron at a temperature not exceeding 150°C



Iron at a temperature not exceeding 200°C



Do not iron



Do not use chlorine bleach



Do not tumble dry



May be tumble dried
(low heat setting)



May be tumble dried
(normal setting)

Fig. A

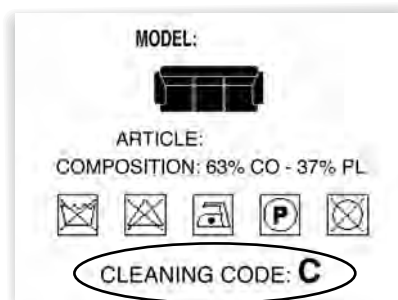

CO Cotton

SE Silk

LI Linen

PA Polyamide

PC Acrylic

PL Polyester

PU Polyurethane

VI Viscose

AC Acetate

4.2.1 THE MICROFIBRE

Microfibre is a type of synthetic fabric obtained by very dense weaving particularly resistant to abrasion and wear and tear that make the covering both practical and elegant.

Cleaning code "A" – Microfibre coverings

The following instructions must be followed to remove stains from the microfibres, depending on the type of stain:

LIQUEURS

Dab with absorbent paper or a white, non-abrasive cloth and then remove the stain. Wash using only colourless, mild soapsuds, obtained by shaking the container vigorously, if the stain persists. Then remove the stain using only 10% denatured alcohol diluted in water.

Dry immediately with warm air using a hair dryer. Direct the jet of warm air from the outside working towards the centre of the damp area.

SOFT DRINKS/WINE

Dab with absorbent paper or a white, non-abrasive cloth and then remove the stain. Remove the stain using only a solution of one part vinegar to one part water if the stain persists. Then wash using only colourless, neutral soapsuds obtained by shaking the container vigorously. Finally dab the soapsuds with a cloth dampened with water. Dry immediately with warm air using a hair dryer. Direct the jet of warm air from the outside working towards the centre of the damp area.

COFFEE/TEA

Dab with absorbent paper or a white, non-abrasive cloth and then remove the stain. If the stain persists, wash using only colourless, mild soapsuds, obtained by shaking the container vigorously. Then remove the stain using only a solution of 10% ammonia diluted in water. Dry immediately with warm air using a hair dryer. Direct the jet of warm air from the outside working towards the centre of the damp area.

BEER

Dab with absorbent paper or a white, non-abrasive cloth and then remove the stain. If the stain persists, remove the stain using only warm water (max 40°C / 104°F) diluted with 3% denatured alcohol in water. Dry immediately with warm air using a hair dryer. Direct the jet of warm air from the outside working towards the centre of the damp area.

OIL

Dab with absorbent paper or a white, non-abrasive cloth and then remove the stain. Wash the stain using only colourless, mild soapsuds, obtained by shaking the container vigorously. Absorb the stain as much as possible using absorbent paper. Remove the stain using a white, non-abrasive cloth dampened only with perchloroethylene, if the stain persists. Absorb as much of the stain as possible with absorbent paper. Dry immediately with warm air using a hair dryer. Direct the jet of warm air from the outside working towards the centre of the damp area.

WARNING

- Position the sofa at least 50 cm. from sources of heat such as heaters or radiators.
- Avoid exposing the sofa to direct sunlight or to powerful lamps to ensure the colour of the covering remains bright.
- To remove dust, brush delicately using a brush with soft bristles or use a vacuum cleaner with the medium power output setting using the most suitable accessory supplied with the cleaner and taking care not to rub the accessory directly against the covering.
- To maintain the aesthetic appearance it is advisable to treat each stain immediately before it becomes absorbed excessively: this will avoid prolonged or abrasive treatments being required.
- If it is found necessary to use solvents, avoid applying the solvents directly on the stain. Pour the solvent onto a clean cloth: each treatment should first be tested on a hidden area of the sofa covering.
- Clean the stain using a circular movement, working from the outside towards the centre.
- Always take care to rub each stain delicately.
- If you purchase a new sofa, with a covering that is an identical article and/or has the same colour as a sofa that you already own, it is possible that you may note slight differences in shades of colour between the two.

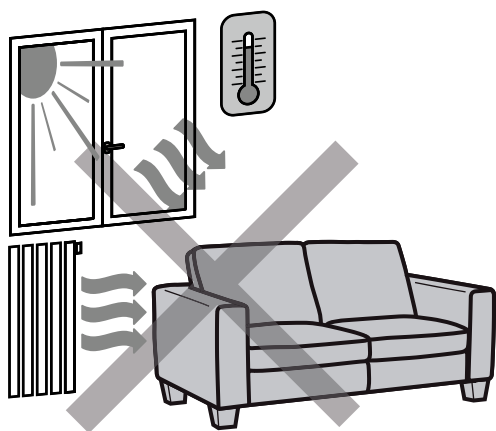

4.2.2 THE FABRIC COVERING

There are two types of washing process for our fabrics: dry cleaning and washing in water.

Dry cleaning is an operation which foresees cleaning the covering material using organic solvents. The process includes cleaning, rinsing and drying. It is essential to iron the covering by following the ironing instructions shown on the label after the washing phase.

Specialist dry cleaners must be used when the covering requires dry cleaning.

Washing in water is an operation which foresees cleaning the fabric covering in water.

The process includes cleaning, rinsing and drying. After washing it is essential to iron the covering by following the ironing instructions shown on the label.

When the covering is washed in water, it is necessary to pay attention to the maximum washing temperature indicated on the sofa label.

WARNING

- Fabrics to be dry cleaned must not be washed in water under any circumstance and fabrics to be washed in water must not be dry cleaned under any circumstance. This operation would not enable the fabrics to be subsequently refitted.

Cleaning category "C" coverings

LIQUEURS, SOFT DRINKS, WINE, COFFEE, TEA, BEER AND OIL

Dab with absorbent paper or a white, non-abrasive cloth and then remove the stain. If the stain persists, clean using a dry stain remover that can be purchased from any supermarket. We recommend that the fabric's reaction be tested on a part of the covering that is hidden before using the stain remover. It is advisable to use a specialised laundry service in the case of large or persistent stains.

WARNING

- Position the sofa at least 50 cm. from sources of heat such as heaters or radiators.
- Avoid exposing the sofa to direct sunlight or to powerful lamps to ensure the colour of the covering remains bright.
- To remove dust, brush delicately using a brush with soft bristles or use a vacuum cleaner at a medium power output setting using the most suitable accessory supplied with the cleaner and taking care not to rub the accessory directly against the covering.
- To maintain the aesthetic appearance it is advisable to treat each stain immediately, before it is absorbed excessively: this will avoid prolonged or abrasive treatments being required.
- If it is found necessary to use solvents, avoid applying the solvents directly on the stain. Pour the solvent onto a clean cloth: each treatment should first be tested on a hidden area of the sofa covering.
- Clean the stain by adopting a circular movement, working from the outside towards the centre.
- Always take care to rub each stain delicately.
- If you purchase a new sofa, with a covering that is an identical article and/or has the same colour as a sofa that you already own, it is possible that you may note slight differences in shades of colour between the two.

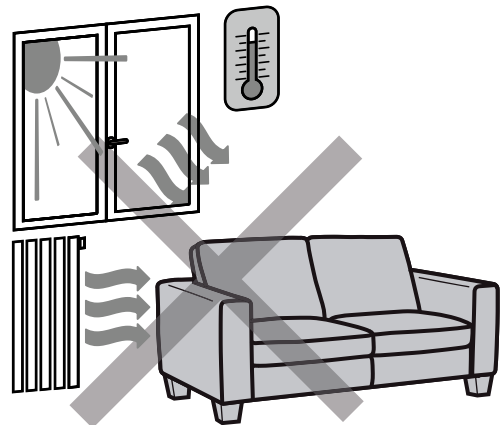

5. THE RELAX FUNCTIONS

5.1 ARMCHAIRS AND SOFAS WITH MANUAL MECHANISM

Armchairs and sofas with a reclining mechanism offer the possibility of changing the inclination of the back, positioning the legs horizontally and changing the seating position. If you have purchased an armchair or a sofa with the sliding function (Zero Wall), you will also have the possibility of reclining the armchair or sofa without having to move the upholstered furniture away from the wall. In fact, the seat and back move forward during extension, thanks to a special mechanism.

If you have purchased a swivelling armchair, in addition to the reclining function you will have the rocking chair function and can turn the armchair about its vertical axis. If you have purchased a product with armrest or headrest with “ratchet”, you can recline them with a simple manual movement.

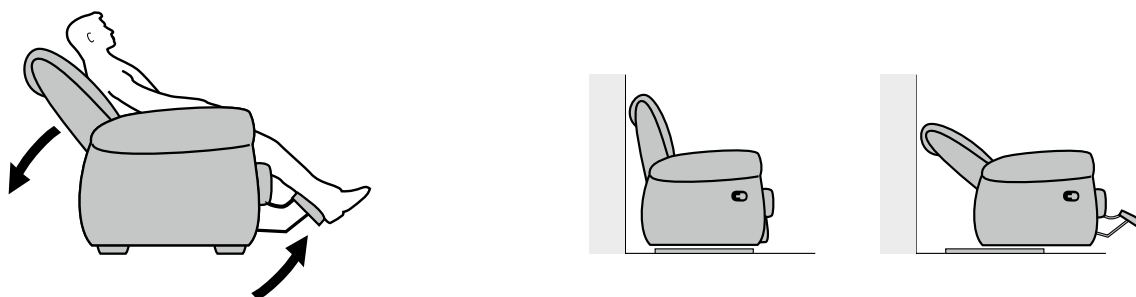

USE

The means of using the reclining functions vary depending on the models.

5.1.1 RECLINING WITH DORSAL PRESSURE

The armchair can be made to recline by simply placing the arms on the armrests (1) and pressing the back against the backrest (2). The armchair is returned to the upright position by moving the trunk forward and accompanying the footrest to the initial position by exerting pressure with the legs.

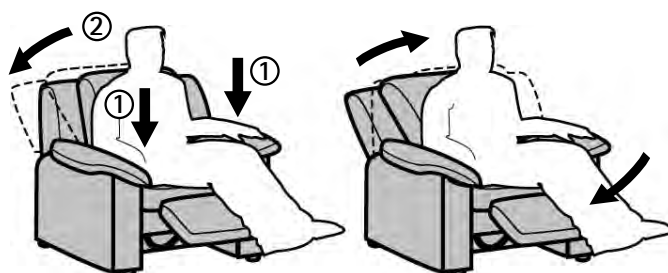

5.1.2 RECLINING WITH EXTERNAL HANDLE

The extension mechanism is achieved by using the handle positioned on the outside of the armrest. Pulling the handle causes the footrest to extend. The armchair is made to recline fully by exerting pressure with the trunk. The armchair is returned to its upright position by moving the trunk forward and accompanying the footrest back to the initial position by exerting pressure with the legs.

If you have purchased a sofa with a central reclining seat, the opening handle is positioned between the cushions.

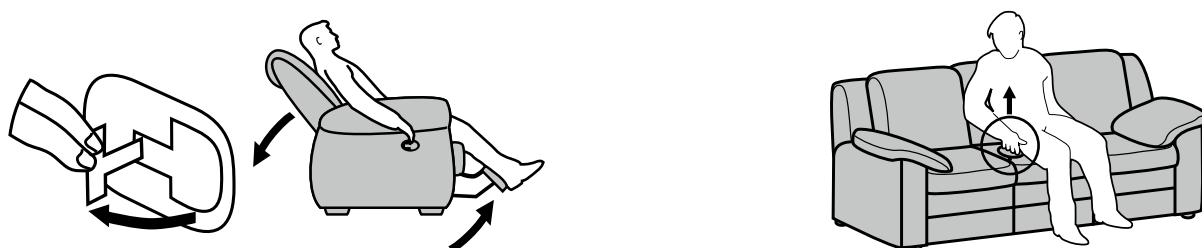

5.1.3 RECLINING WITH INTERNAL HANDLE

The extension mechanism is achieved by using the handle positioned on the inside between the armrest and the seat. Pulling the handle causes the footrest to extend. The armchair is made to recline fully by exerting pressure with the trunk. If you have purchased a sofa with a central reclining seat, the opening handle is positioned between the cushions.

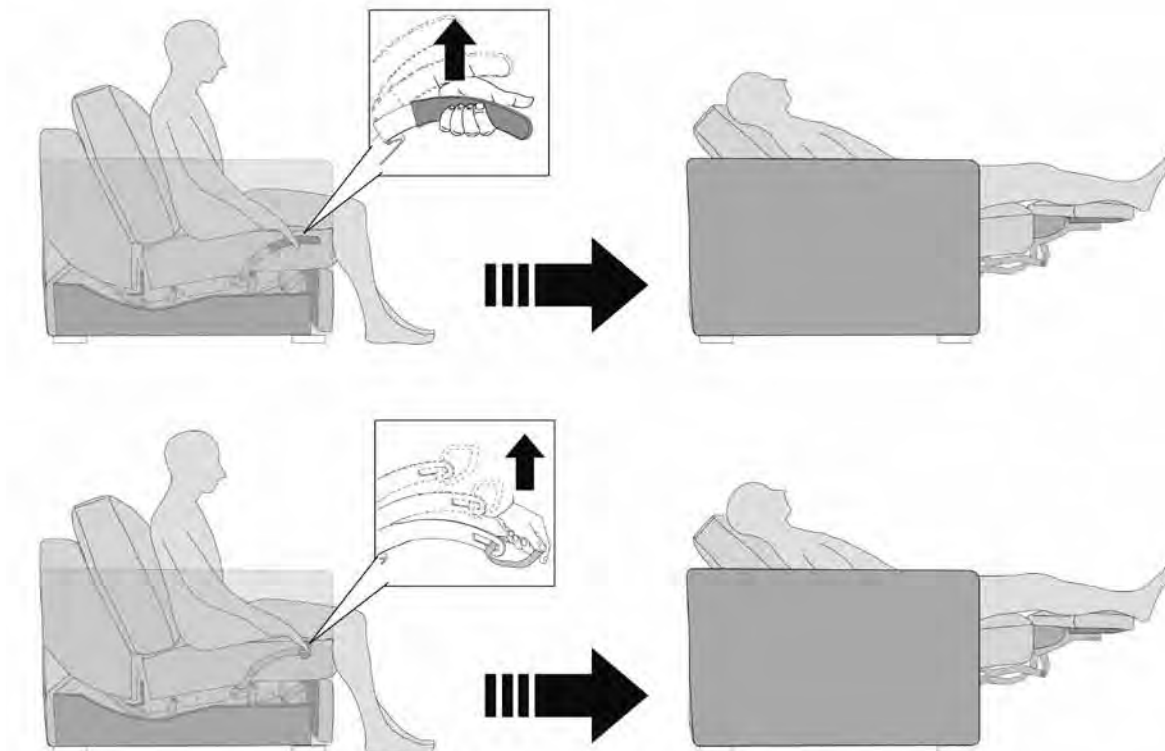

If you have purchased an armchair with reclining headrest, you must raise this before moving the lever.

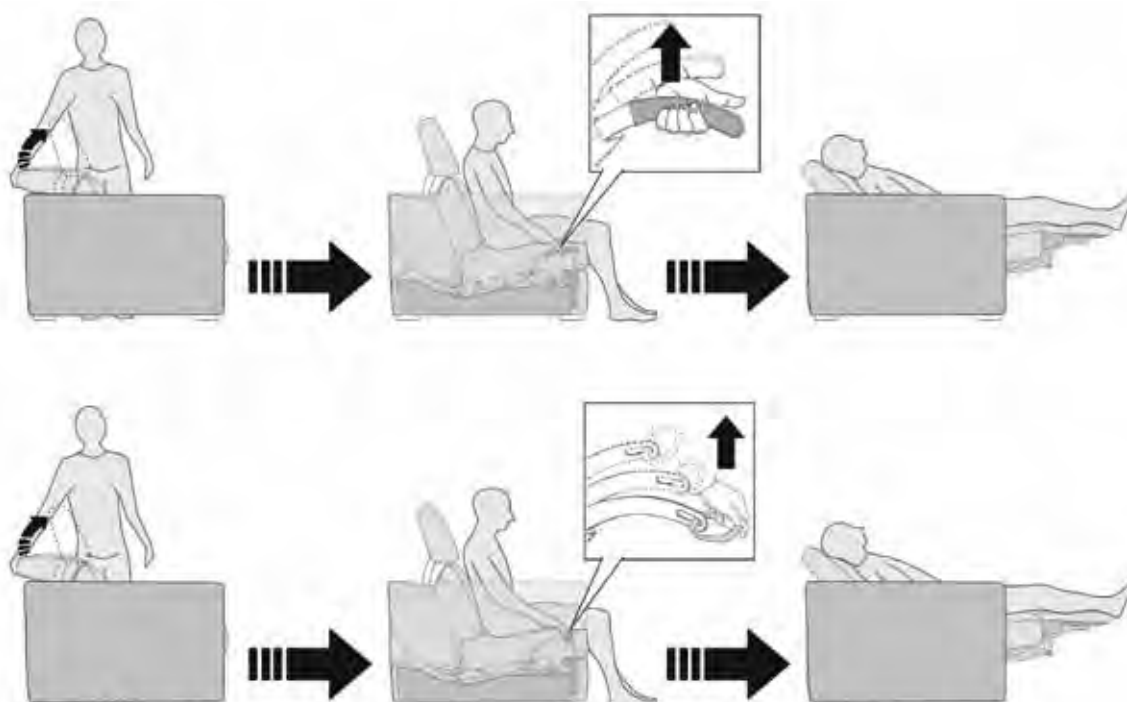

The armchair is returned to its upright position by moving the trunk forward and accompanying the footrest back to the initial position by exerting pressure with the legs.

5.1.4 RECLINING WITH SLIDING FUNCTION

The models with sliding functions are equipped with an opening mechanism that is activated by exerting pressure on the seat cushion. The armchair is returned to its upright position by accompanying the seating cushion back to the initial position by exerting pressure with the legs.

OPENING

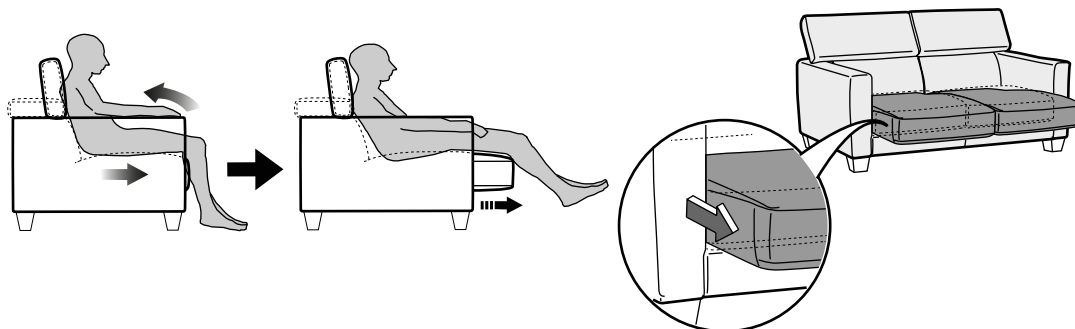

CLOSING

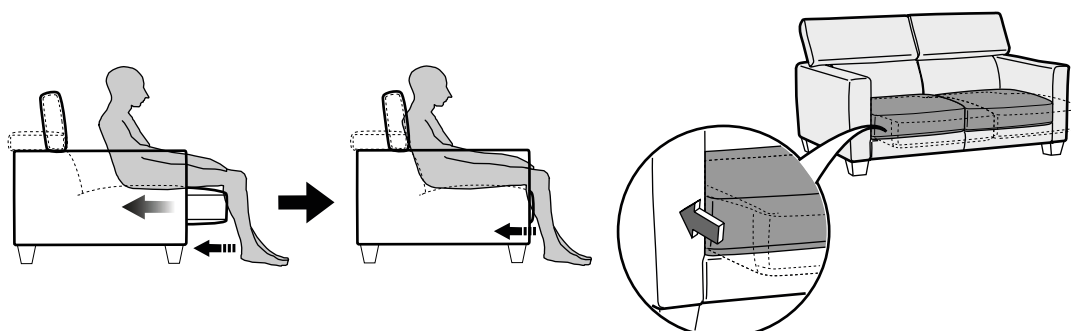

5.1.5 RECLINING WITH ARMREST AND HEADREST

These models are equipped with a manual “ratchet” mechanism that allows you to regulate the inclination of the headrest or the armrest as you desire. To return the armrest or the headrest to the initial position you first need to extend it fully and then apply pressure in the opposite direction.

OPENING

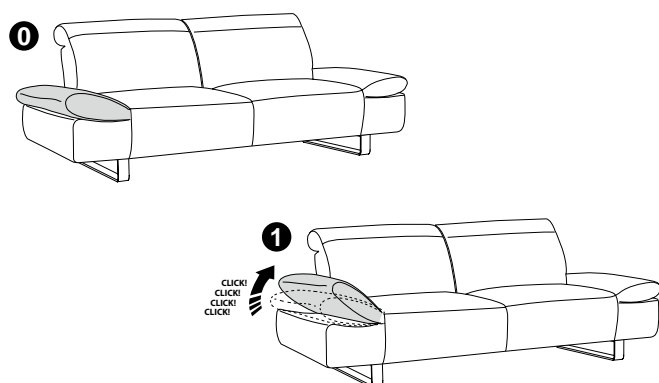
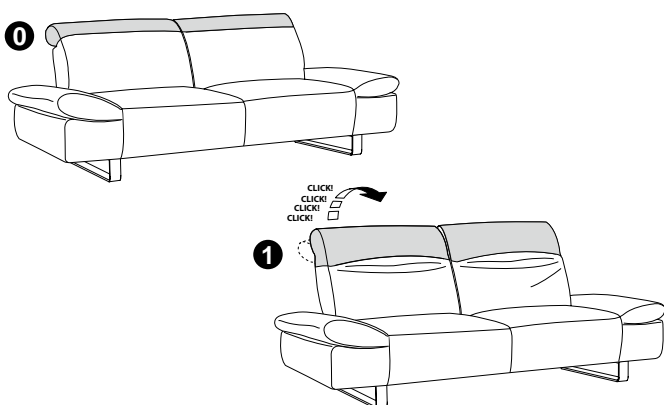

CLOSING

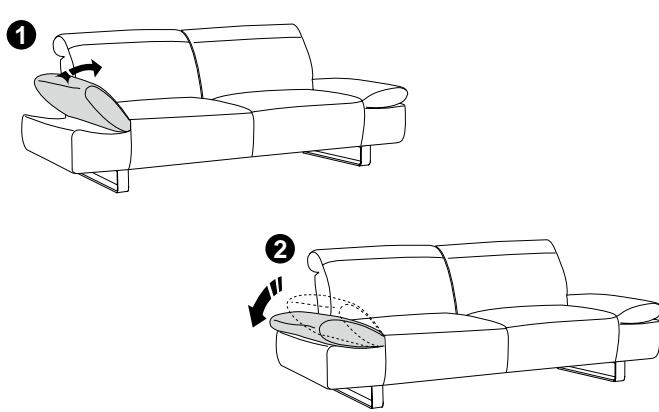
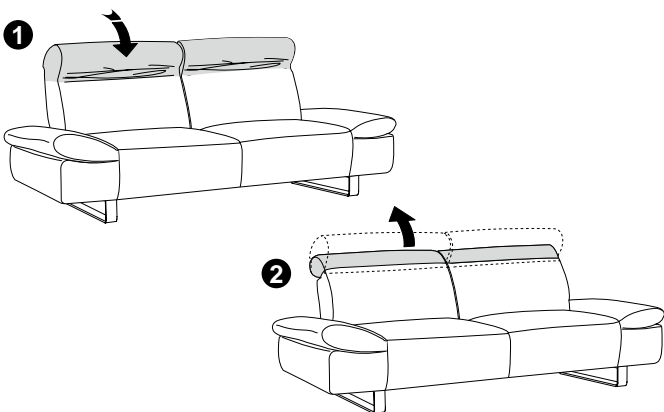

5.1.6 ARMCHAIR WITH ROTATING FUNCTION

The rotating function, where present, can always be used. In fact, no device needs to be operated to make this function available. It is sufficient to rest the feet on the ground and exert a sideways pressure to turn. This function is only available in armchairs.

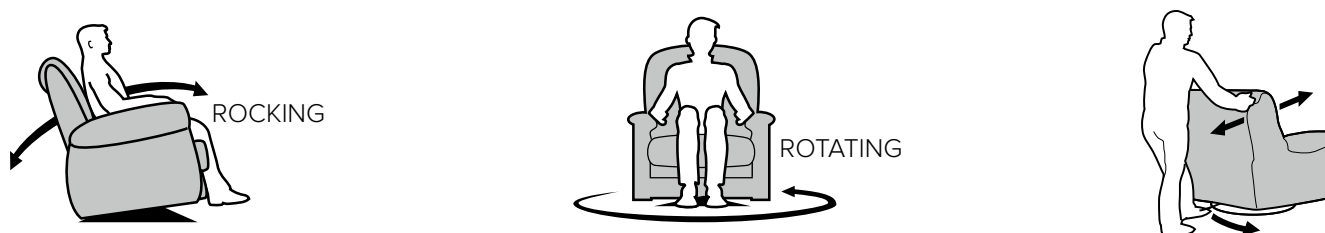

5.1.7 ARMCHAIR WITH ROCKING CHAIR FUNCTION

The rocking chair function can be activated by moving the lever positioned behind the armchair to the left, or this function is activated automatically when the lever is operated to activate the reclining mechanism. The rocking chair function is locked by moving the lever positioned behind the armchair to the right and at the same time by moving the backrest slightly to allow the locking bayonet to be correctly inserted in position.

WARNING

- Before using our products with a mechanism incorporated, check whether the mechanism is restrained by a plastic strap. If the strap has been applied, it must be cut. (Side figure)
- Do not use solvents to clean the metal parts of the mechanism: a damp cloth is sufficient.
- Do not allow children to play with the mechanism.
- The mechanism must only be used when the person is correctly seated.
- Lightly lubricate the springs, the hinges and all the joints using normal spray-on lubricants available on the market, if the mechanism produces squeaks when in operation.
- Tighten the screws that may loosen with use.
- Do not sit on the front edge of the armchairs that have the rocking function, otherwise the armchair could touch the ground and be damaged.

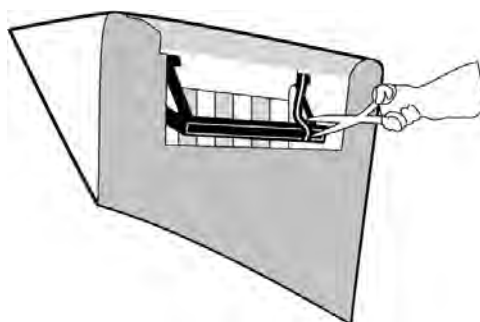

5.2 ARMCHAIRS AND SOFAS WITH ELECTRIC MECHANISM

Armchairs and sofas with an electric mechanism offer the possibility of changing the back inclination, of raising the footrest and of changing the seating position. The back inclination can be adjusted as preferred.

If you have purchased an armchair or a sofa with a sliding function (Zero Wall), you also have the possibility of reclining the armchair or sofa without having to move the upholstered furniture away from the wall. In fact, the seat and the back move forward during the extension phase, thanks to a special mechanism.

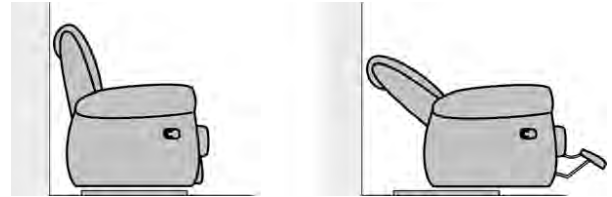

USE

The models with an electric mechanism have a remote control (**Fig. 1**), and/or buttons (**see the following illustration**) that enable a motor to be operated which extends the footrest platform, the headrest and inclines the back to the maximum position allowed.



Fig. 1

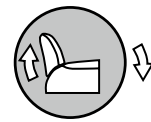

CLOSE



OPEN

WARNING

- Do not use solvents to clean the metal parts of the mechanism: a damp cloth is sufficient.
- Do not allow children to play with the mechanism.
- The mechanism must only be used when the person is correctly seated.
- Do not touch the mechanical parts.
- Do not use the reclining function continuously to avoid the temporary safety block.
- To free the temporary safety block, let the system cool down for 5 minutes to restore the motor to correct working order.
- Voltage fluctuations may cause the electric motor to cut-off. In this case disconnect the plug from the wall socket, wait for a few minutes and then replace the plug in the wall socket.
- Remove the plug before touching the mechanism when cleaning or performing other operations.

5.2.1 RECLINING ELECTRIC MODEL WITHOUT HEADREST

MODEL WITH TOUCH BUTTON

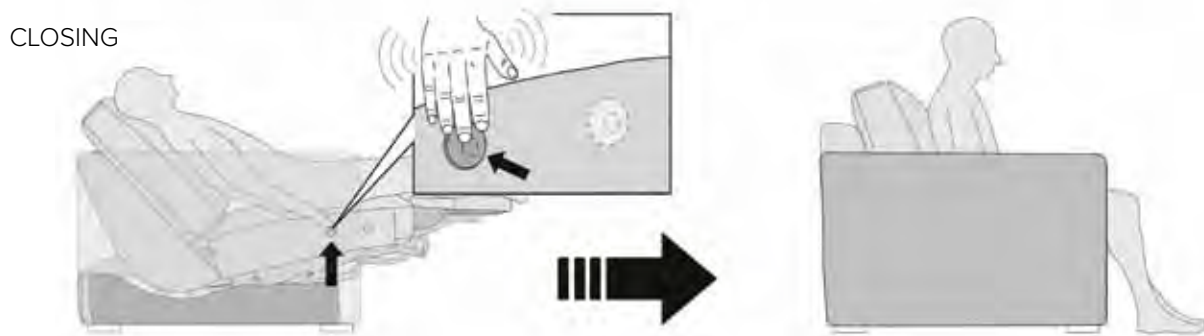
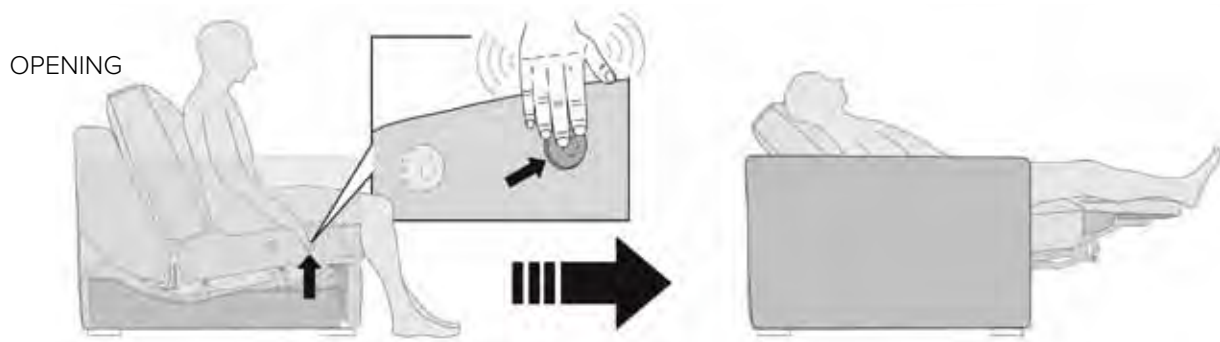

MODEL WITH TWO BUTTONS

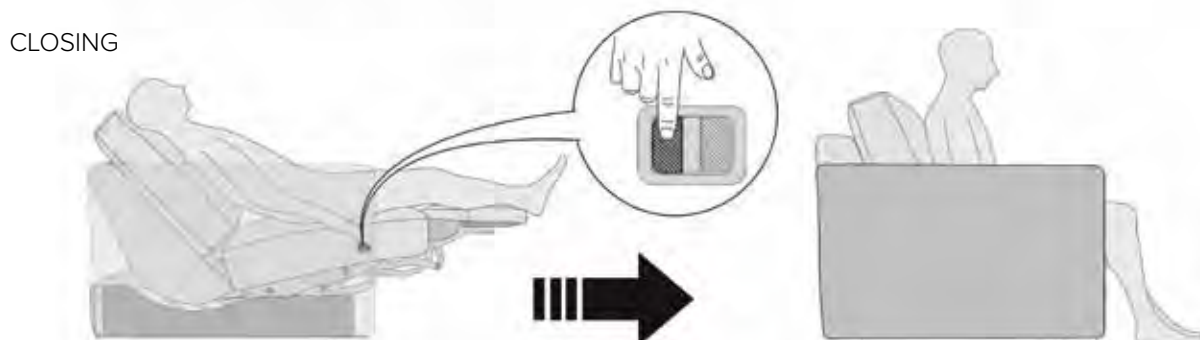
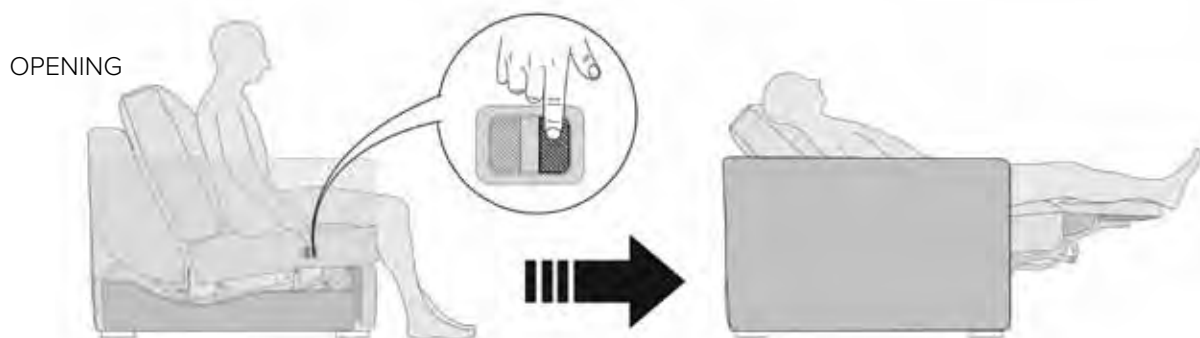

5.2.2 RECLINING ELECTRIC MODEL WITH MANUAL OPENING OF HEADREST

MODEL WITH TOUCH BUTTON

OPENING



CLOSING

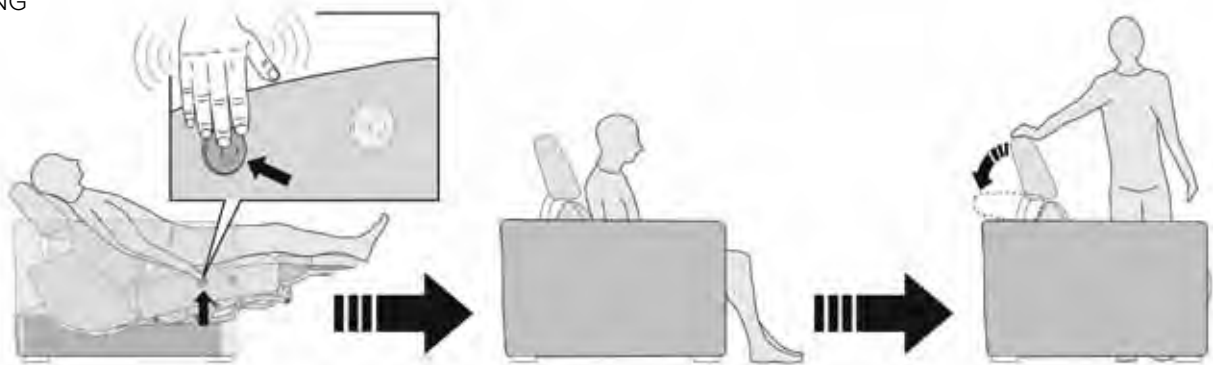

MODEL WITH TWO BUTTONS

OPENING



CLOSING

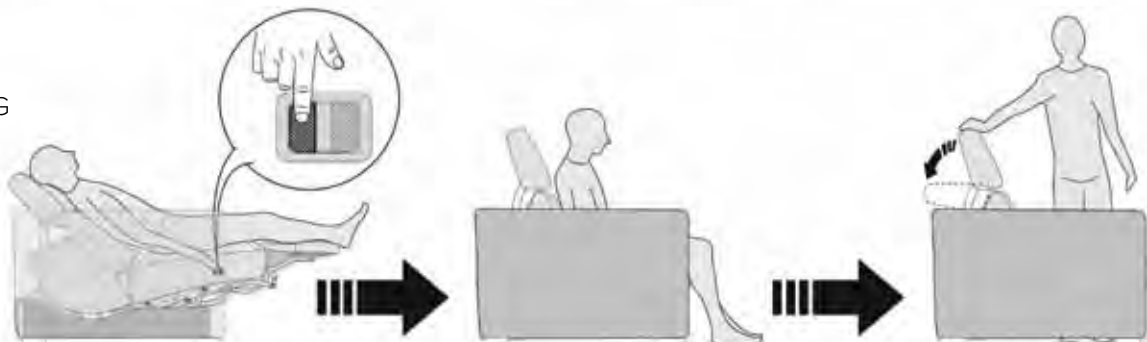

5.2.3 RECLINING ELECTRIC MODEL WITH ELECTRIC OPENING OF HEADREST

MODEL WITH TOUCH BUTTON

OPENING

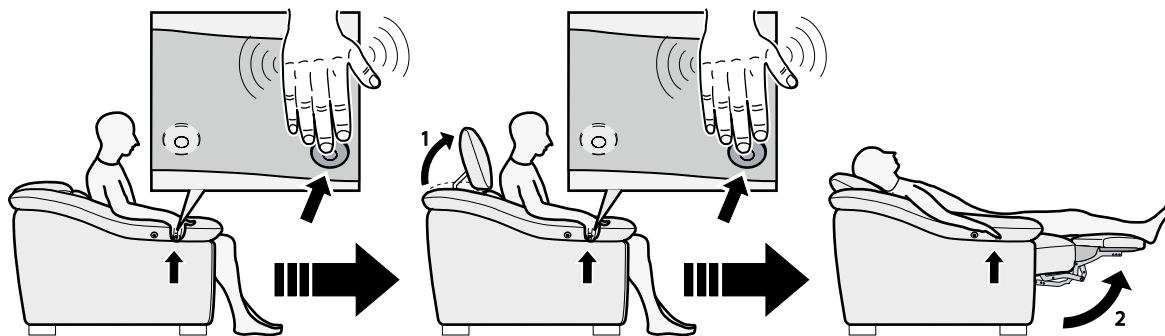

CLOSING

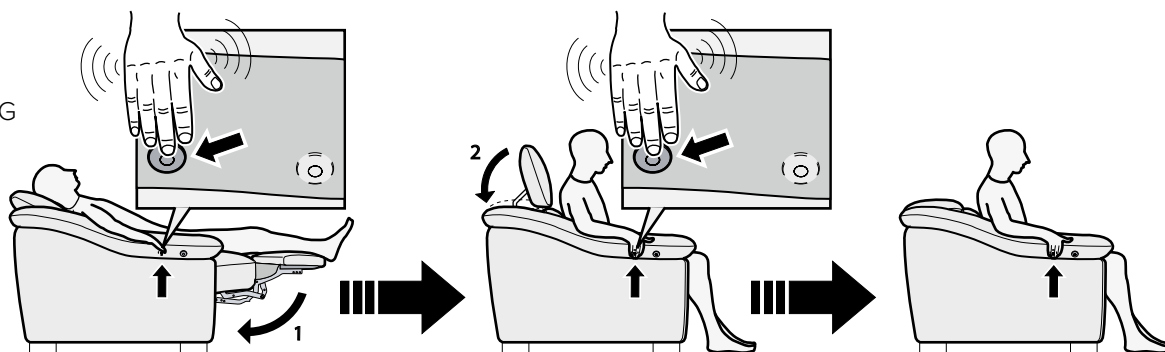

MODEL WITH FOUR BUTTONS

OPENING

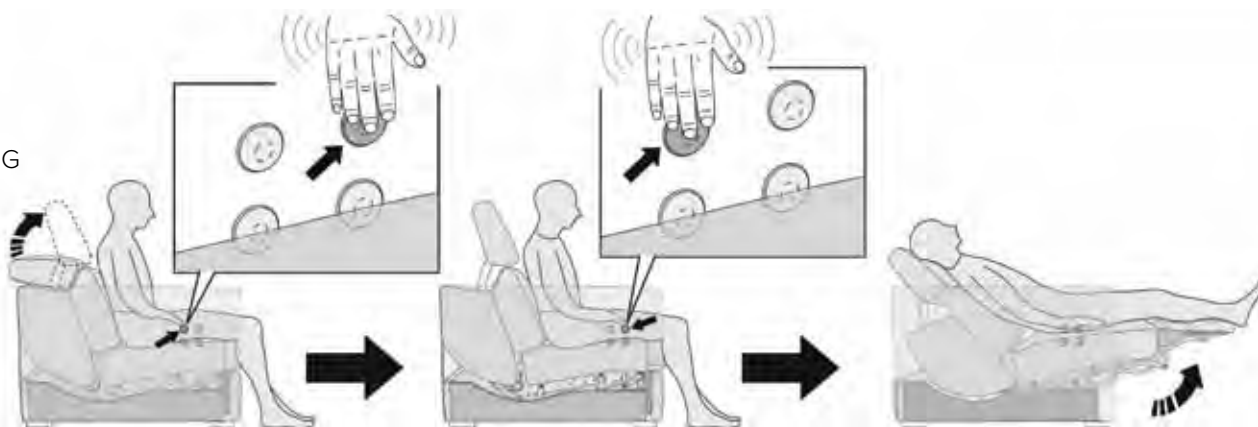

CLOSING

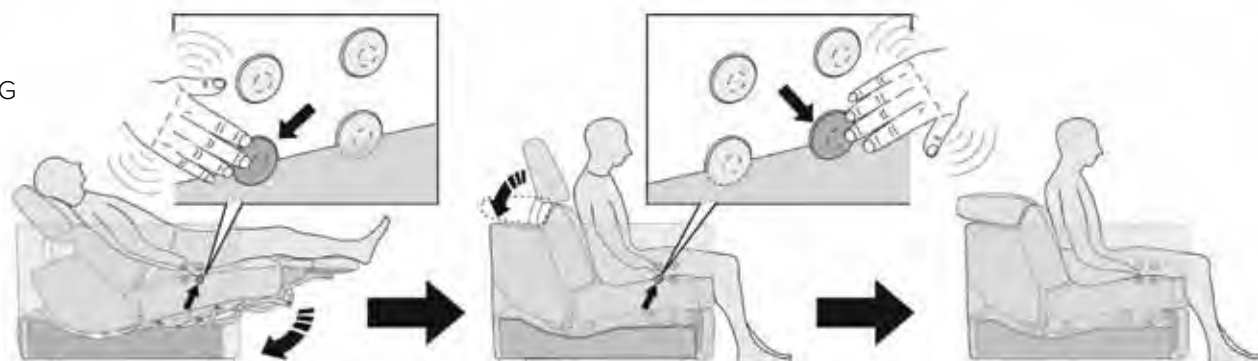

5.2.4 MODEL WITH ELECTRIC SLIDING FUNCTION

MODEL WITH TOUCH BUTTON OPENING

OPENING

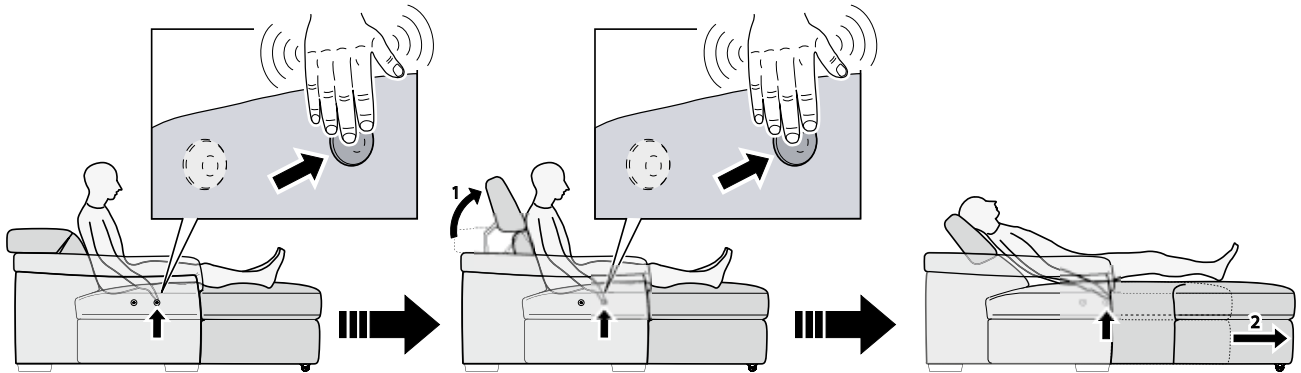

CLOSING

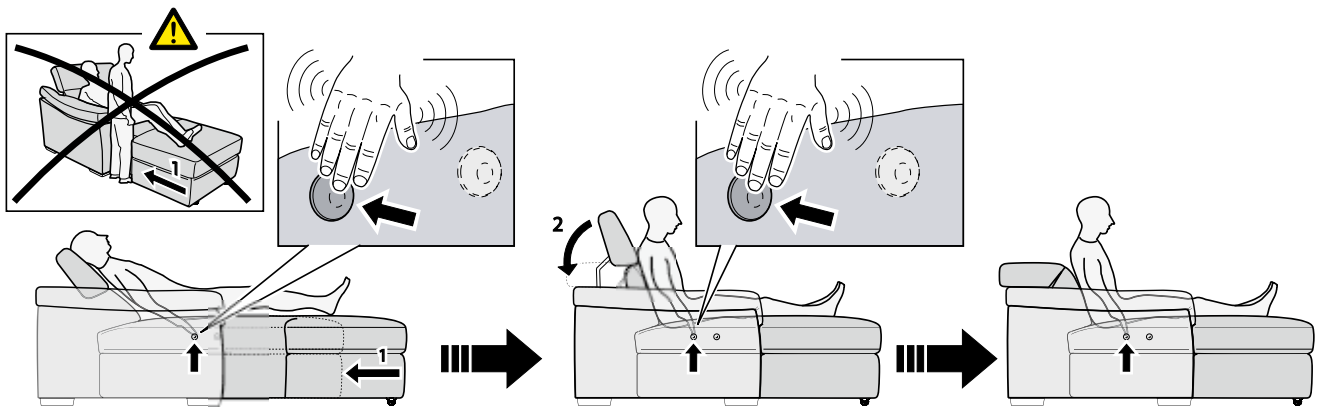

5.3 ARMCHAIRS AND SOFAS WITH SOFT TOUCH ELECTRIC MECHANISM

Armchairs and sofas with the soft touch electric mechanism offers you the possibility of changing the back inclination, of raising the footrest and of changing the seating position via slight pressure exerted on hidden sensors in the outer side part of the armrest. The inclination of the back can be regulated, as you desire, you can choose to block the mechanism in the desired position without having to open it completely.

USE

The models with the soft touch electric mechanism have capacitive buttons that allow you to activate a motor that opens the footrest platform, the headrest and the back to the maximum extension allowed.

5.3.1 MODEL WITH SOFT TOUCH ELECTRIC MECHANISM

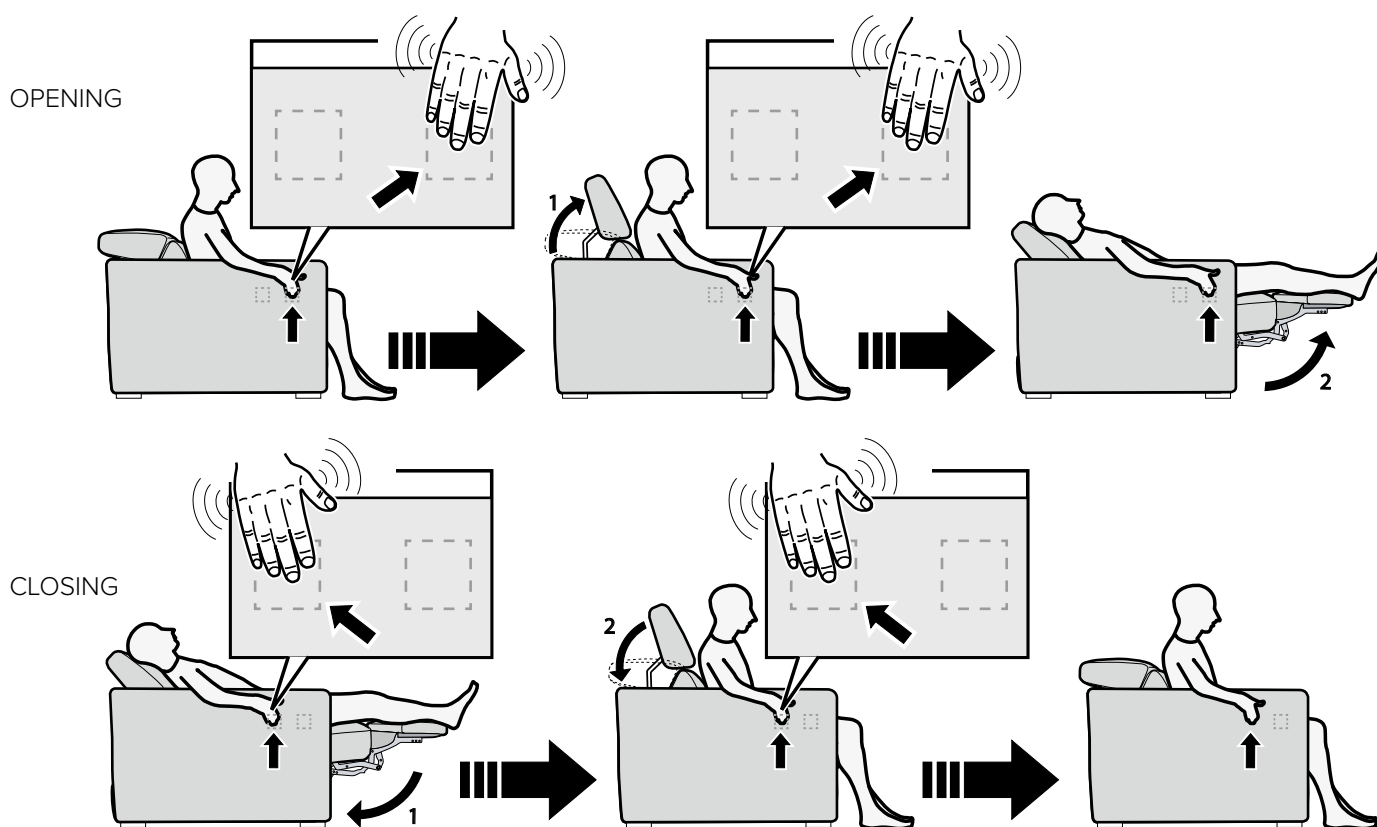

5.3.2 MODEL WITH ELECTRIC SOFT TOUCH CHAISE LONGUE

OPENING

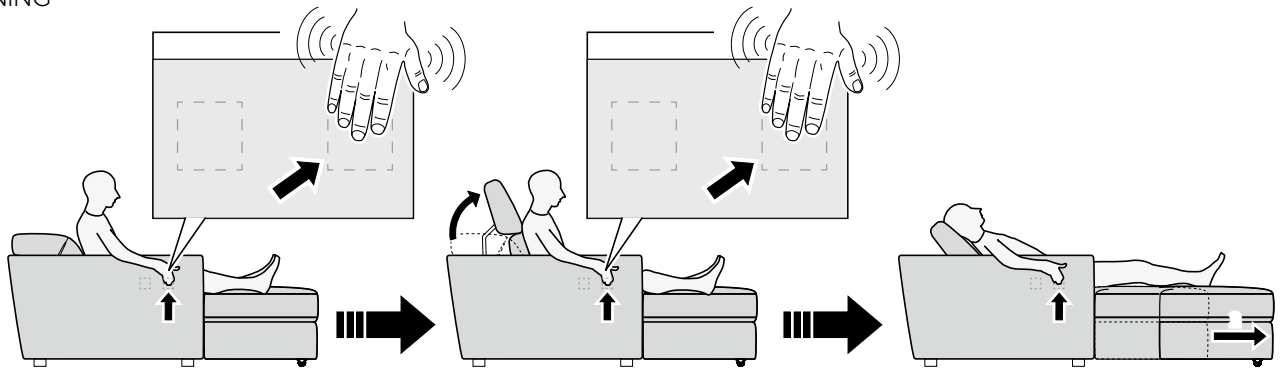

CLOSING

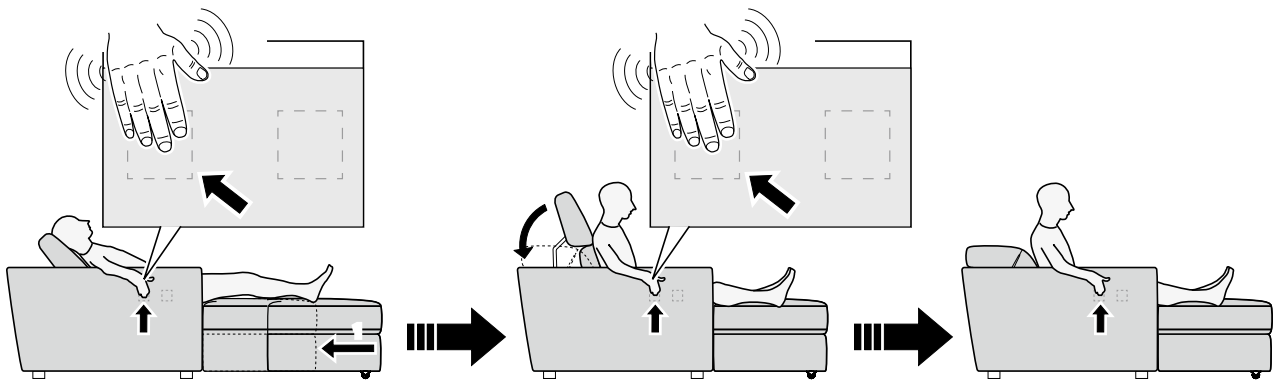

WARNING

- Do not use solvents to clean the metal parts of the mechanism: a damp cloth is sufficient.
- Do not allow children to play with the mechanism.
- The mechanism must only be used when the person is correctly seated.
- Do not touch the mechanical parts.
- Allow the system to cool down for 5 minutes to restore the motor to correct working order.
- Voltage fluctuations may cause the electric motor to cut-off. In this case disconnect the plug from the wall socket, wait for a few minutes and then replace the plug in the wall socket.
- Remove the plug before touching the mechanism when cleaning or performing other operations.

6. ARMCHAIRS AND SOFAS WITH AUDIO FUNCTIONS

6.1 ARMCHAIRS WITH AUDIO FUNCTIONS

By connecting an mp3 player to the hidden minijack cable, you can listen to music in comfort when seated thanks to the audio speakers in the headrest.

Main features of the audio kit:

- Dual output 25-watt amplifier
- 60-watt transformer
- 2 x double-cone 25-watt speakers,
100 mm in diameter
- 4 ohm impedance
- 3.5 mm minijack cable

Verify the compatibility of the electronic devices that are connected to the docking station both in terms of connection and software present in the utilised devices (given that the devices undergo continual evolution).

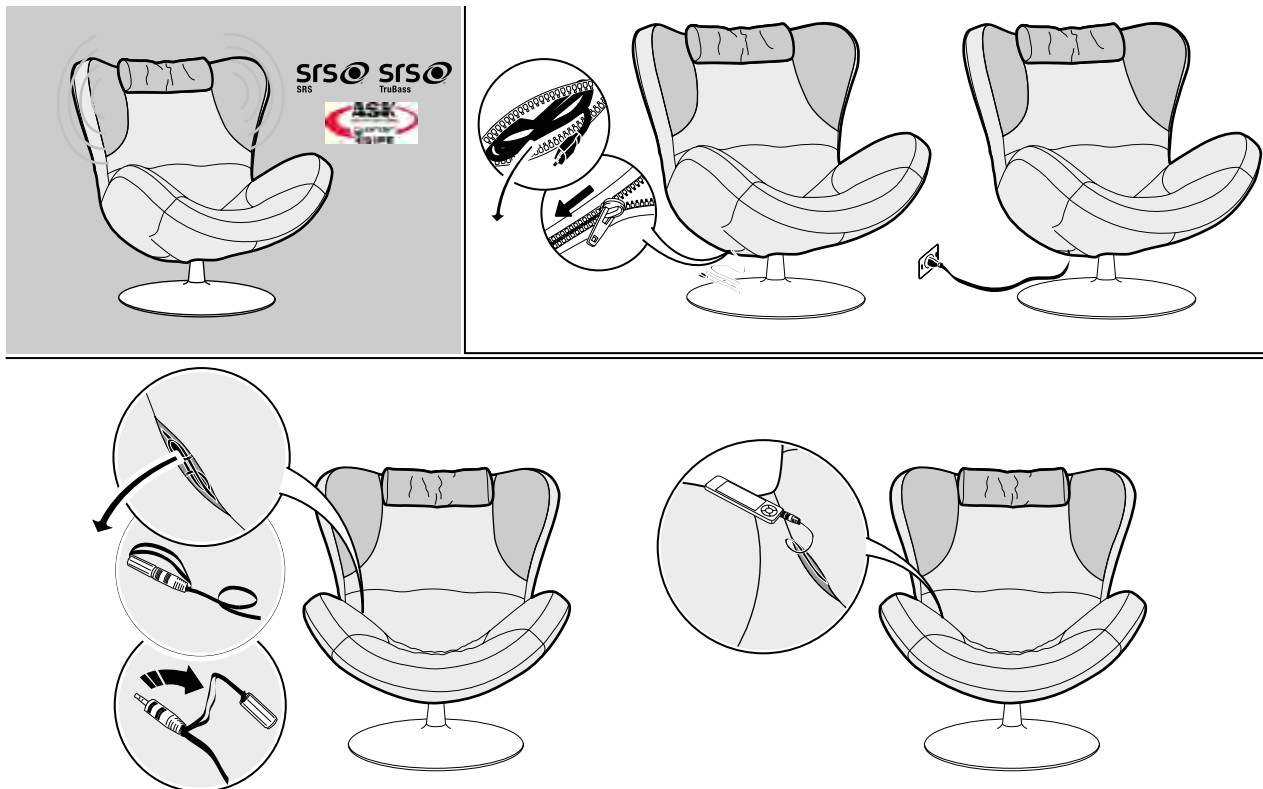

6.2 SOFAS WITH AUDIO FUNCTIONS

The sofas with audio functions are equipped with speakers and a docking station for iPhone or iPod.

Main features of the audio kit:

- Dual output 25-watt amplifier
- 60-watt transformer
- 2 x double-cone 50-watt speakers
- 165 mm in diameter
- 4 ohm impedance
- Universal docking station for iPod
- iPhone, iPod touch, iPod Nano
- Remote control

Verify the compatibility of the electronic devices that are connected to the docking station both in terms of connection and software present in the utilised devices (given that the devices undergo continual evolution).

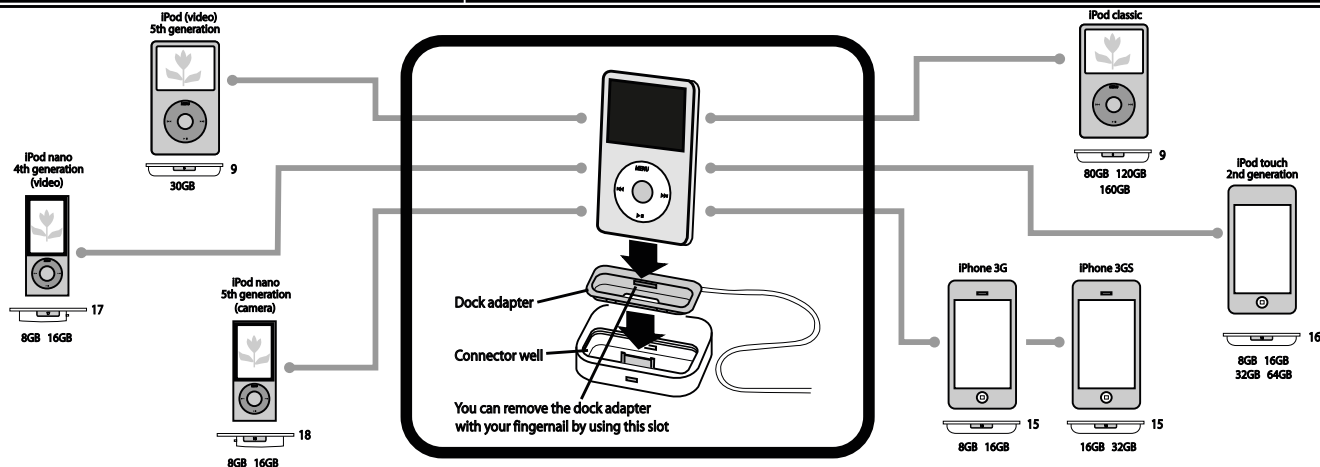
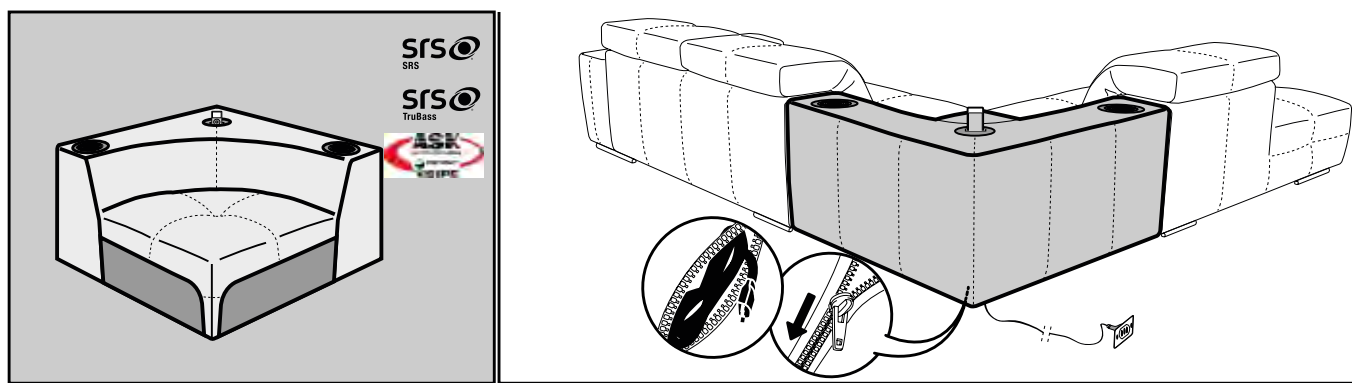

WARNING

- For correct functioning of the audio sofa we recommend that you do not cover or place any weights on the docking stations and the speakers.

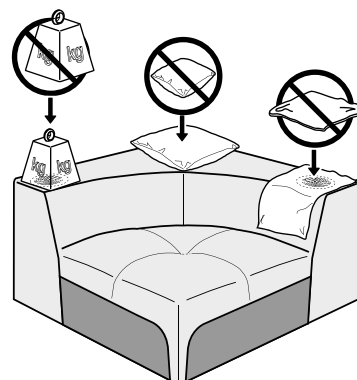

7. ARMCHAIRS AND SOFAS WITH ELECTRIC MASSAGE

VERSION WITH DUAL MASSAGE

These products are equipped with a mechanism inside the back that has a massage function exerting a stretching movement (lengthening) and a massage with a circular action (kneading). The electric reclining function is always available.

THE STRETCHING MESSAGE

Stimulates the circulation through a movement exerted in vertical lines. Delicate stretching of the muscles releases the pressure from the spinal disks.

MASSAGE WITH THE CIRCULAR ACTION

Relaxes the back and neck muscles. Eliminates the feeling of stiffness and fatigue.

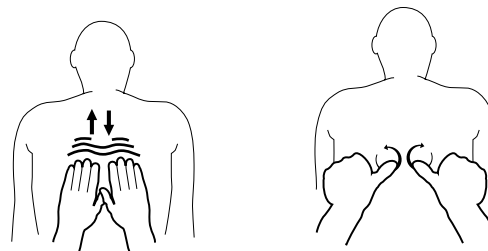

Use

Models with the massaging mechanism have a remote control unit that enables the massage functions to be activated. Moreover, the same remote control operates the motor, which opens out the footrest platform and inclines the back to the maximum position allowed

AUTOMATIC MASSAGING MANAGEMENT

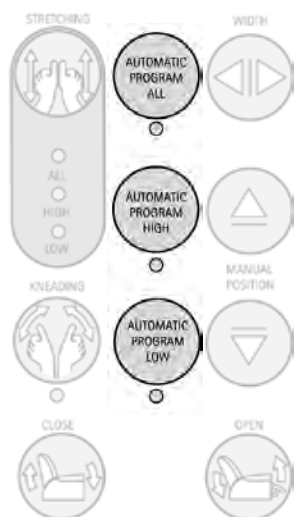

These buttons activate the combined stretching and circular (kneading) massage programmes: complete, high and low.

MANUAL MASSAGE MANAGEMENT

Amplitude adjustment of the stretch massage function

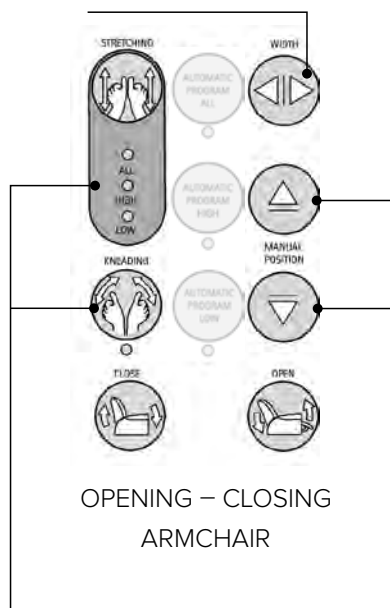

Activating stretching and circular action (kneading): complete, high and low.

Manual positioning of the massaging unit.

VERSION WITH TRIPLE MESSAGE

This version has the same functions as the models with two types of massage, with the additional shiatsu localised pressure massage (tapping). This function comprises a localised pressure movement that invigorates the back muscles.

Use

Models with the massaging mechanism have a remote control unit that enables the massage functions to be activated. Moreover, the same remote control operates the motor, which opens out the footrest platform and inclines the back to the maximum position allowed.

AUTOMATIC MASSAGING MANAGEMENT

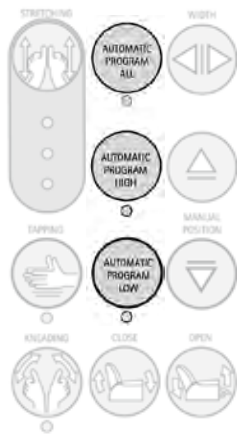

These buttons activate the combined stretching with circular (kneading) and shiatsu localised pressure (tapping) massage programmes: complete, high and low.

MANUAL MASSAGE MANAGEMENT

Amplitude adjustment of the stretch massage function

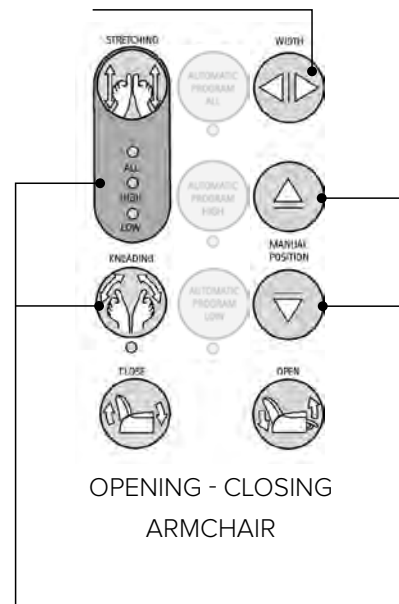

Stretching, circular (kneading) and localised pressure (tapping) massage activation: complete, high and low.

Manual positioning of the massaging unit.

WARNING

- Do not use solvents to clean the metal parts of the mechanism: a damp cloth is sufficient.
- Do not allow children to play with the mechanism.
- The mechanism must only be used when the person is correctly seated.
- Do not touch the mechanical parts.
- Do not jump on the armchair.
- Press the Stop button before getting up when the massage function is in operation.
- Use by pregnant women and people with back problems is not recommended.
- Do not use the reclining function continuously to avoid the temporary safety block.
- To free the temporary safety block, let the system cool down for 5 minutes to restore the motor to correct working order.
- Any given selected massage function can have a maximum duration of 15 minutes, at the end of which the system automatically stops. The system must then remain inactive for 5 minutes.
- Voltage fluctuations may cause the electric motor to cut-off. In this case remove the plug from the wall socket, wait for a few minutes and then reinsert the plug in the wall socket.
- Remove the plug from the wall socket before touching the mechanism when cleaning or performing other operations.

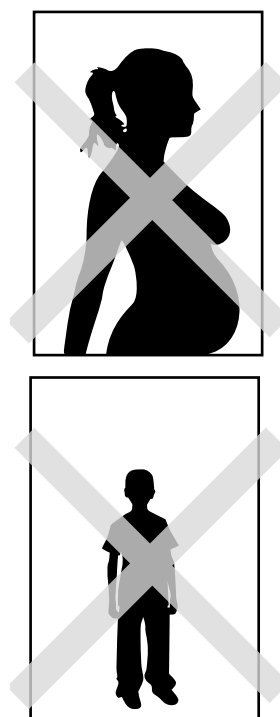

8. THE BED MODELS

A number of our sofa models can be used as comfortable beds, if need be. A number of types of bedsprings are available: “DOUBLE FOLDING”, “TRIPLE FOLDING”, “TRANSFORMABLE”, “READY BED”.

USE

8.1 DOUBLE FOLDING BEDSPRINGS

Double folding bedsprings are equipped with a variable inclining headrest. The following operations have to be performed to open up the double folding bedsprings:

- Remove the seat cushions. If a leather strip covers the upper edge of the bedspring, this strip must be folded forward to protect the sofa covering.

- Raise the bedspring by gripping the central handle and pulling outwards, resting the support bar on the floor. **Fig. 1**



Fig. 1

- Grip the second supporting bar in the centre of the bar, raise and accompany the bar until it touches the floor.

Fig. 2

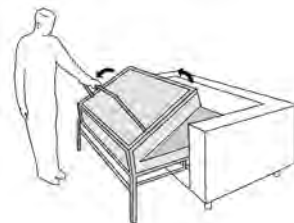

Fig. 2

- Lift the headrest raising it up to the first notch. The headrest is lowered by lifting it over the notch and releasing it slowly back to its initial position. **Fig. 3**



Fig. 3

- The bed is closed by repeating the same operations in reverse order. Re-position the leather strip after the operations to close the bedspring have been completed, if there is a leather strip.

8.2 TRIPLE FOLDING BEDSPRINGS

The following operations have to be performed to open up the triple folding bedsprings:

- Remove the seat cushions. If a leather strip covers the upper edge of the bedspring, this strip must be folded forward to protect the sofa covering.

- Raise the bedspring by gripping the central handle and pulling outwards. Grip the first supporting bar at the centre of the bar, raise and accompany the bar until it touches the floor. **Fig.1**



Fig.1

Repeat the operation for the second supporting bar. **Fig.2**

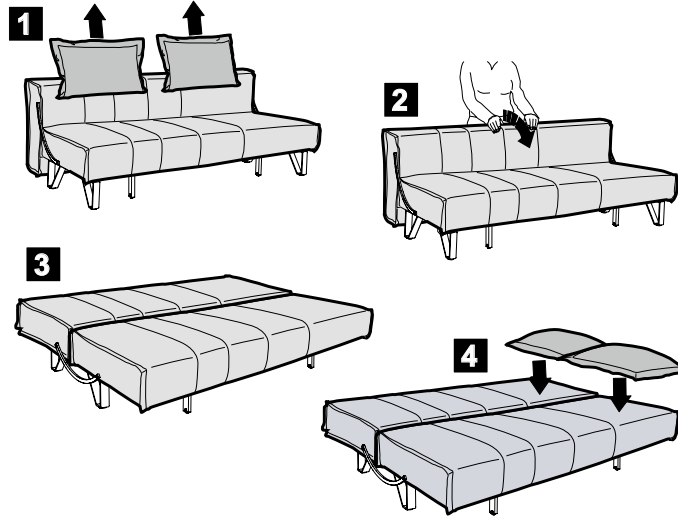
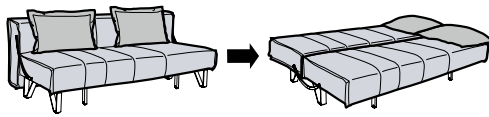
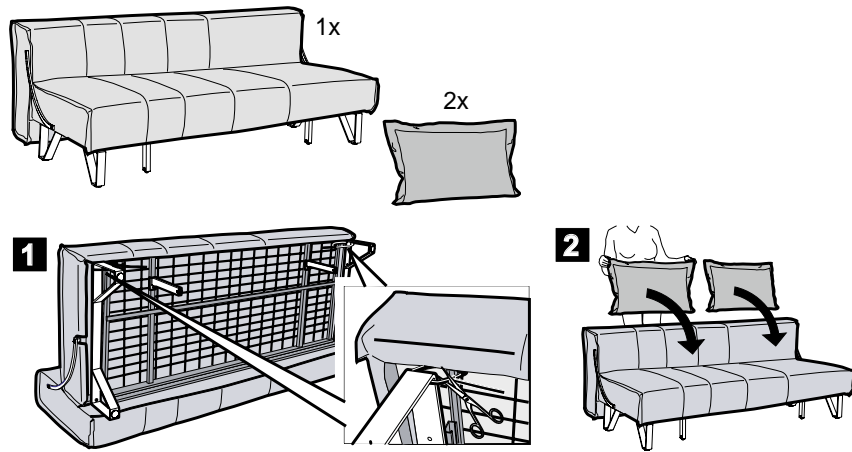

Fig.2

- The bed is closed by repeating the same operations in reverse order. Re-position the leather strip after the operations to close the bedspring have been completed, if there is a leather strip.

8.3 TRANSFORMABLE SOFA BED

OPENING



CLOSING

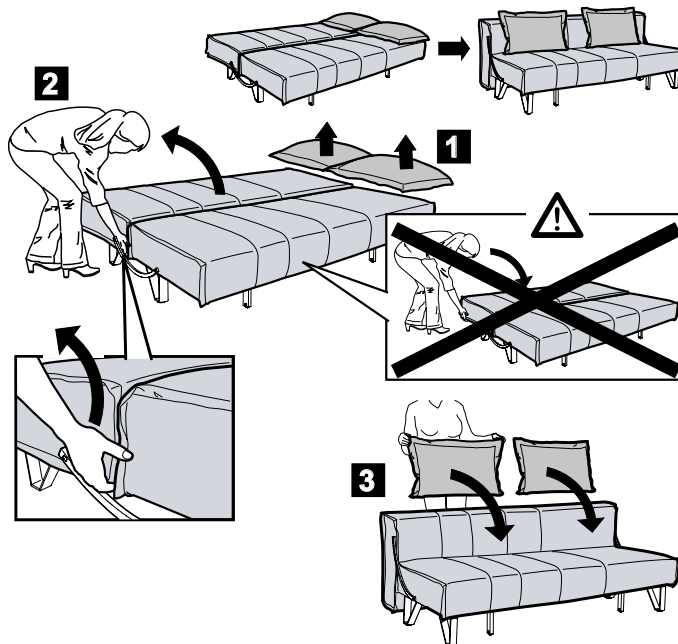

8.4 READY-BED SOFA

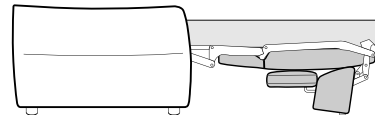
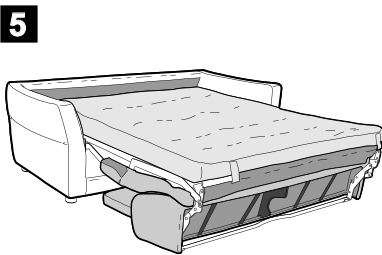
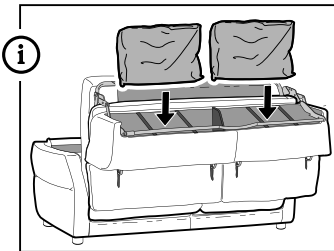
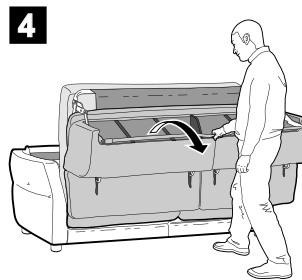
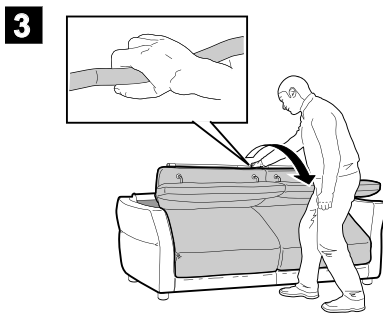
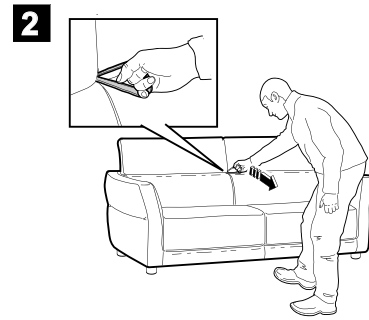
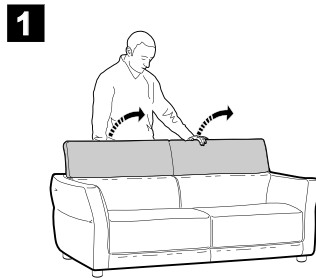
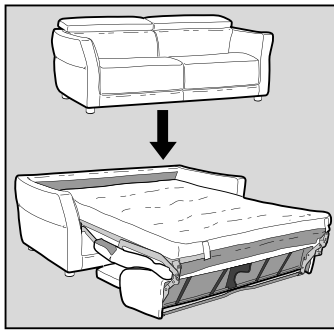

WARNING

- Before using our products that incorporate a mechanism, it is necessary to cut the safety tab that restrains the mechanism.
- Remove the polystyrene insert which prevents oscillations of the bedspring during transportation.
- Do not use solvents to clean the metal parts: a dry cloth is sufficient.
- Do not allow children to play with the mechanism.
- Remove the bed sheets and blankets before closing the bedspring.
- Avoid sitting on the edge at the foot of the bedspring (Fig.1)
- Do not sit or stand on the head of the bedspring.
- If the sofa is equipped with a ratchet, lift the ratchet and then open the bed (Fig.2) (Fig3)

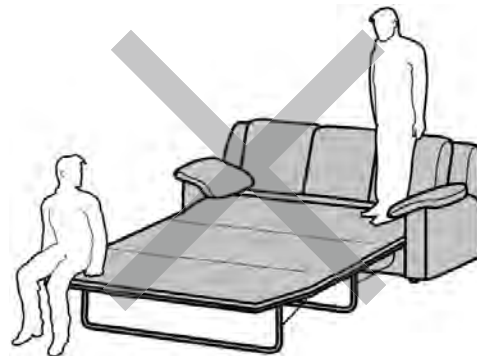

Fig. 1

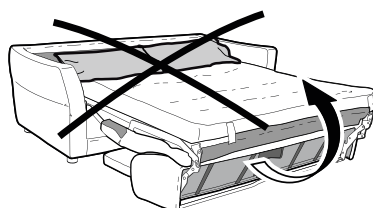
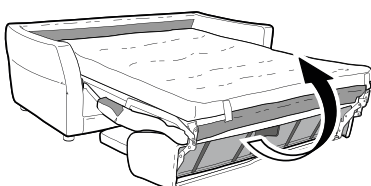

Fig. 2

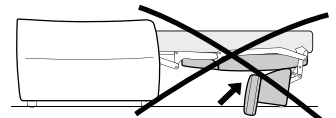
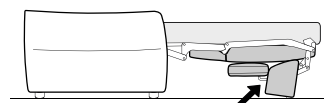

Fig. 3

9. MODELS WITH REMOVABLE COVERINGS

PRODUCT FEATURES

Sofas with removable coverings are designed to enable the covering to be removed easily for washing. The attention we pay to the customer and our excellent service is also demonstrated for this product line by its many small details:

- The fabrics have been carefully selected to ensure their technical and aesthetic characteristics remain unaltered after repeated washing.
- The cushions and the sofa's structure are covered with practical covers that facilitate introduction of the external covering and can be conveniently fastened using Velcro.
- The feet have a slot in which the covering can be inserted to avoid the feet being partially hidden when they are positioned on the outside edge of the sofa.
- The sofa is supplied with a special palate that facilitates insertion of the covering under the feet and a protective Velcro strip to make handling the covering easier.

Preserve these items carefully, they will be very useful when you remove and replace the sofa covering.

- The model with a removable covering may have different stitching, heights and particulars compared to the same mode that has a fixed covering equipped with variable inclining headrest.

9.1 USE

DOUBLE FOLDING BEDSPRINGS

The following operations have to be performed to open up the double folding bedsprings:

- Remove the seat cushions. If a leather strip covers the upper edge of the bedspring, this strip must be folded forward to protect the sofa covering.

9.2 WASHING METHODS

DRY CLEANING

Our fabrics can be dry cleaned, this operation foresees cleaning using organic solvents and ensures the same efficiency as washing in water. The process includes cleaning, rinsing and drying. The process includes cleaning, rinsing and drying. After washing it is essential to iron the covering by following the ironing instructions detailed on the label.

WASHING IN WATER

Washing in water is an operation which foresees cleaning the covering using water.

The process includes cleaning, rinsing and drying. After washing it is essential to iron the covering by following the ironing instructions detailed on the label. When washing in water it is necessary to pay attention to the maximum temperature, as detailed on the sofa label.

WARNING

- **Fabrics to be dry cleaned must not be washed in water under any circumstance. This operation would not enable the fabrics to be subsequently refitted.**

9.3 INSTRUCTIONS TO REMOVE THE SOFA COVERING

Phase 1: if your model has small side straps, bows, other finishings or accessories (**Fig. A**), these must be removed or unhooked.



Phase 2: remove all the cushions, unfasten the zips and remove the coverings (**Fig. B**).

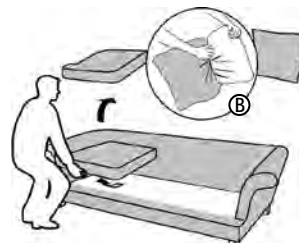

Phase 3: unfasten the zip positioned behind the back, if present (**Fig. C**). Remove the covering from the groove if the sofa has feet positioned on the outside edge (**Fig. D**).

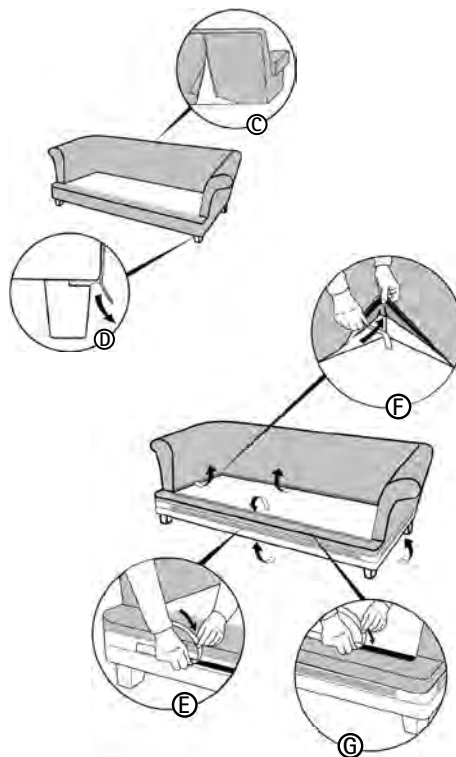

Phase 4: detach the Velcro, reverse the covering along the sofa's outside edge starting from the corners and protect the edge using the strip supplied (**Fig. E**). Reverse the covering carefully to avoid damaging the stitches. Repeat the same operations along the covering's internal edge (**Fig. F and G**).

Phase 5: carefully remove the covering starting from the corners, proceeding alternately for a few centimetres from one side of the sofa to the other. Then remove the covering completely from the sofa.

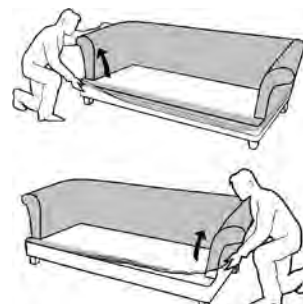

WARNING

- **Do not remove the protective strip: this strip must be attached during washing. The strip must only be removed after the sofa has been relined and should be preserved carefully for further washes.**

9.4 INSTRUCTIONS TO REPLACE THE SOFA COVERING

Phase 1: position the covering on the back and on the armrests to start the covering process and arrange the covering so that the stitching is in line with the corners of the sofa, after the zips that may be present have been unfastened. Stretch the covering by proceeding from the back towards the sofa's front section until the sofa has been completely re-covered. Fasten the zips.

Phase 2: position the covering on the edge of the bottom corner – backrest – armrests remove the strip and fix the Velcro (**Fig. A**). Position the covering on the front part of the seat to ensure the Velcro coincides with the joint between the two covers (**Fig. B**).

Phase 3: stretch the covering over the external parts of the sofa, remove the strip and fix the Velcro along all the sofa edge by turning the covering under the base (**Fig. C**)

Phase 4: insert the covering inside the groove with the help of the palate supplied if the foot is designed as shown in figure D. Re-cover the cushions taking care to arrange the padding in the right direction. The stitching on the cushion's internal cover must correspond to the zip on the covering (**Fig. F**).

Ensure that the zip tab is inserted in its relative holder (**Fig. G**). Firstly, position the side cushions and then the central cushions if you are covering a sofa that has more than two cushions.

Do not invert the position of the cushions on the sofa.

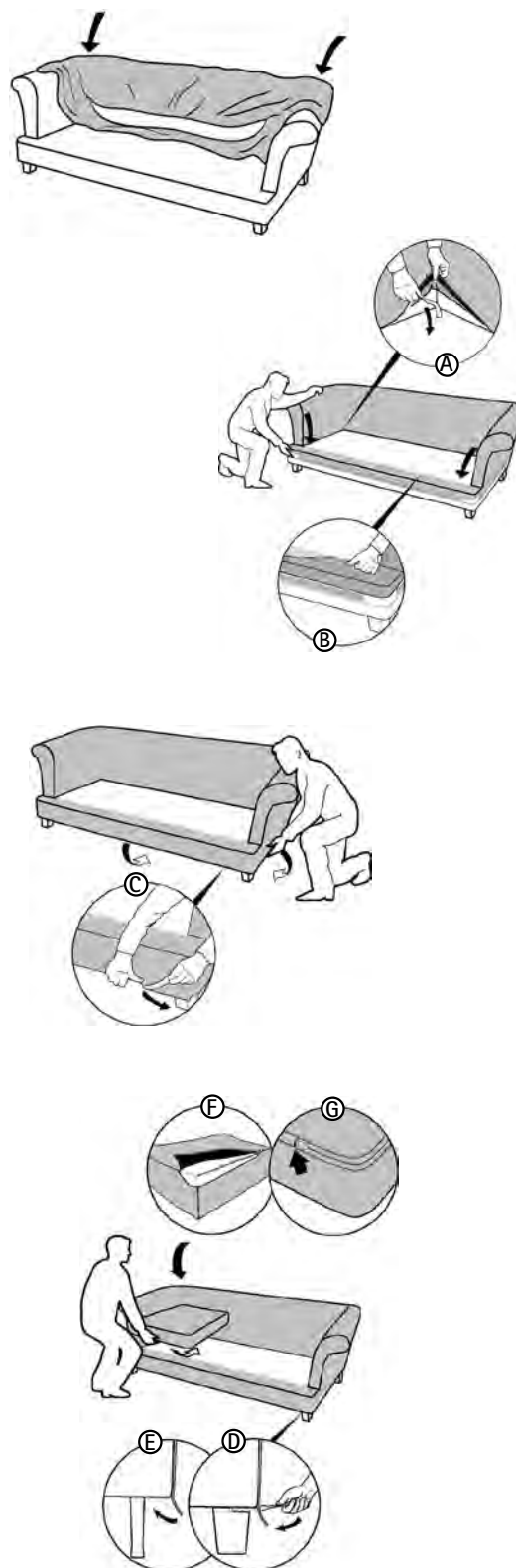

9.5 INSTRUCTIONS TO REMOVE AND REPLACE THE COVER FOR A SOFA OR BED WITH FIXED BACK AND FASTENED SEATING CUSHIONS

Phase 1: Pull the back of the sofa from the back to the front, rotating it, lift the mattress and unfasten the fixing strips.

To re-cover, fasten the fixing strips of the mattress.

Phase 2: Separate the Velcro strips and then remove the covering from the edge of the bedsprings. To re-cover, fasten the Velcro strips and slip on the cover on the edge of the bedsprings.

Phase 3: Reposition the sofa in the standard position and remove the seating cushions. To reassemble, position the seating cushions with the sofa in the standard position.

Phase 4: Rotate the back of the sofa, remove the Velcro in the indicated points and completely remove the cover from the filling. To re-cover, slip on the cover on the back, working from the bottom to the top.

Phase 5: Open the bedsprings completely to remove the cover. To re-cover, open the bedsprings completely and arrange the cover lining up the stitching with the sofa edges.

Phase 6: Starting from the ends, lift the cover uniformly until it is completely removed. To re-cover, partially open the sofa bed, rest the cover on the rear part of the armrests and arrange it so that the stitching is lined up with the sofa edges.

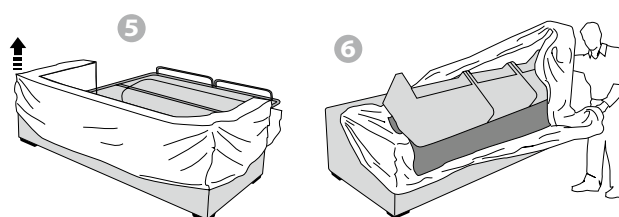
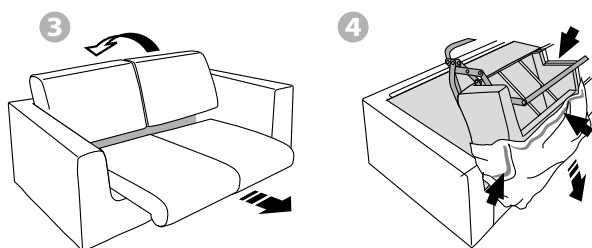
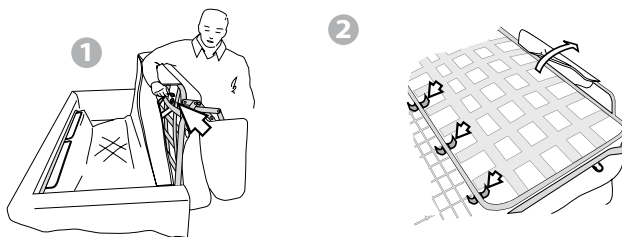

10. SECTIONAL MODELS

PRODUCT FEATURES

This product line enables your sofa to be freely composed according to every personal space requirement. The following illustration shows an example of an arrangement obtained using only a few components: sofa with left armrest, corner piece, sofa without armrest and chaise lounge.

The connection between the components can be achieved in various ways depending on the model:

- with a metal dowel,
- with a plastic bracket,
- with a metal bracket,
- with a universal metal tab.

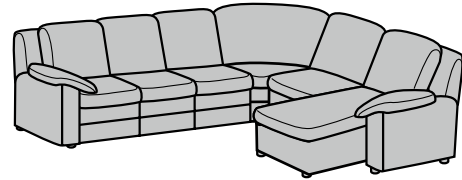

10.1 INSTRUCTIONS FOR METAL DOWEL ASSEMBLY

The connection system consists of a dowel to be fitted on the left-side component (1), which must be inserted in the drilled plate of the right-side component (2).

ASSEMBLY

Align the component parts, ensuring that the dowel is inserted in the hook-up components on the right side, and position the component parts close together until they are firmly connected.

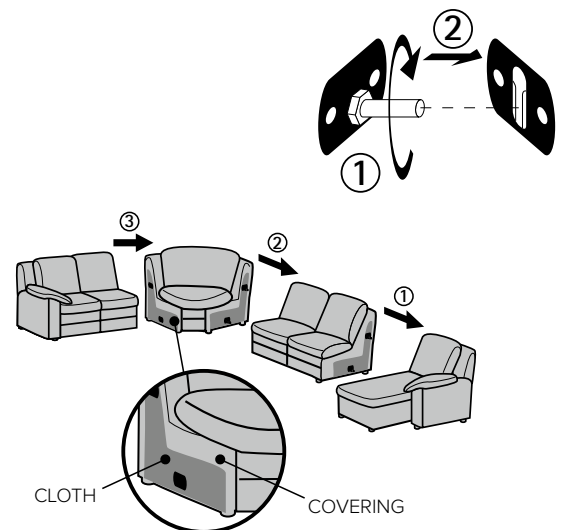

DISASSEMBLY

Raise (3) and separate the left-side component until it is completely free.

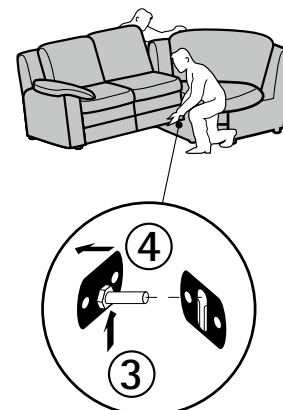

WARNING

- Do not lift and move the sofa while it is still connected.
- The dowels have to be fitted on the right-side component in several versions: in these cases follow the instructions detailed in the illustrating leaflet attached to the sofa.
- Each individual piece making up a complete version is covered on the matching sidepieces facing the cover and not with the relative finish covering.
- When fixed and reclining versions are combined a misalignment of approximately three centimetres will be noted in the rear/lower part of the sectional sofa due to technical design reasons.

10.2 INSTRUCTIONS FOR PLASTIC BRACKET ASSEMBLY

The connection system consists of a dowel to be fitted on the left-side component (1), which must be inserted in the drilled plate of the right-side component (2).

ASSEMBLY

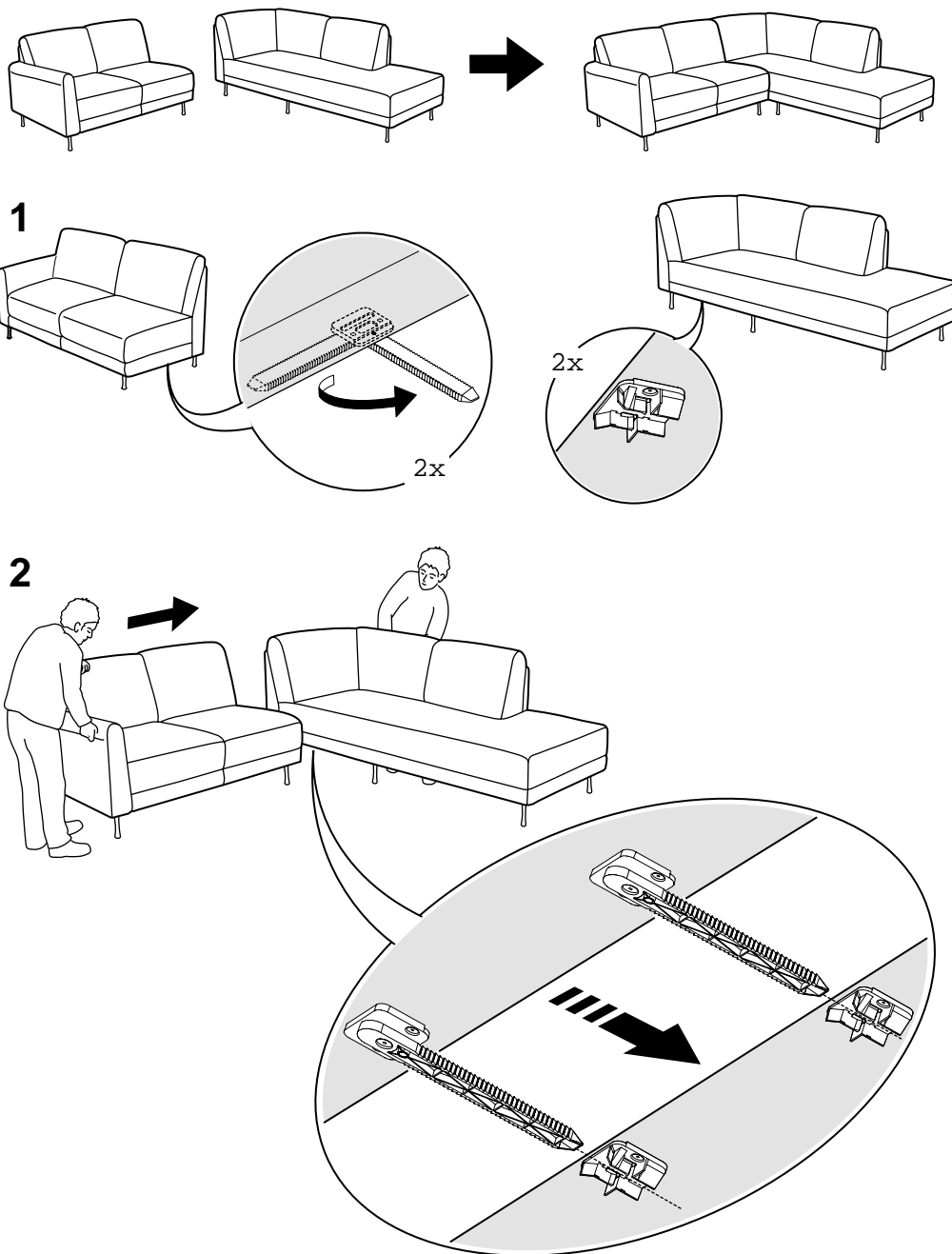

DISASSEMBLY

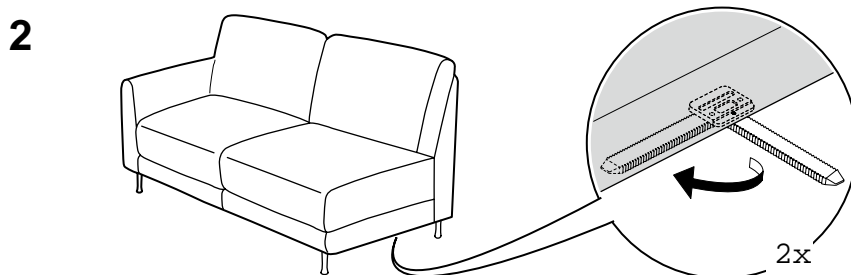
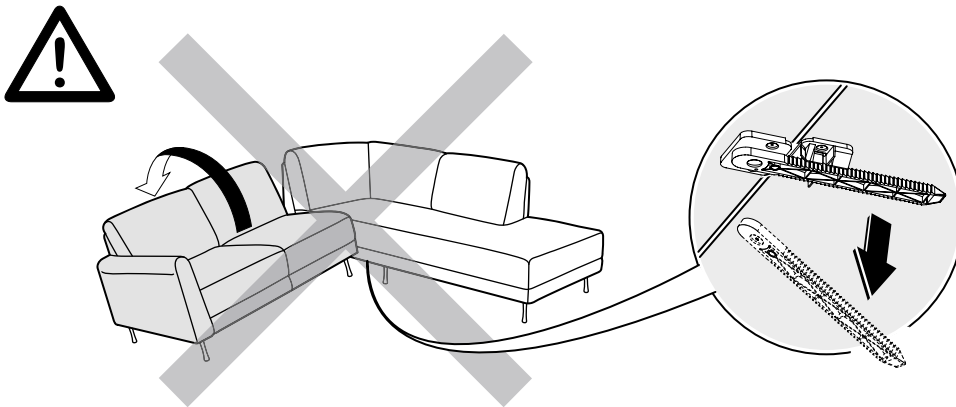
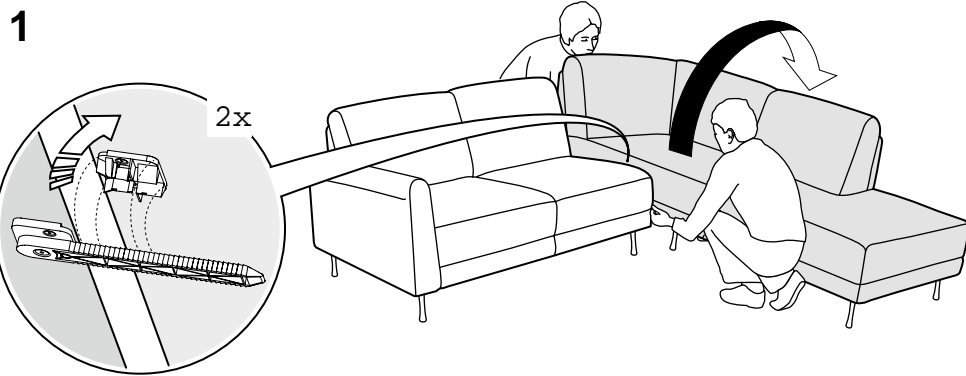
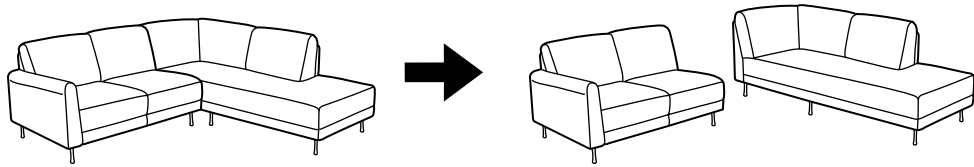

WARNING

- Do not lift and move the sofa while it is still connected.
- Do not lift the left-side component, to avoid detaching the connecting lever: if this occurs it is possible to reposition the connecting lever in its housing.
- THE LEVERS MAY BE FITTED IN A DIFFERENT WAY IN CERTAIN VERSIONS: IN THESE CASES FOLLOW THE INSTRUCTIONS DETAILED IN THE ILLUSTRATING LEAFLET ATTACHED TO THE SOFA.

10.3 INSTRUCTIONS FOR UNIVERSAL TAB ASSEMBLY

The connecting system consists of a single metal component for the left and right versions, mounted on the modular side.

ASSEMBLY

Line up the components and fit the connecting tab lifting the left piece onto the right piece.

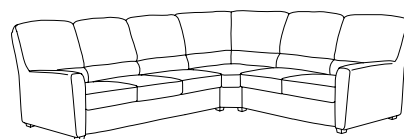
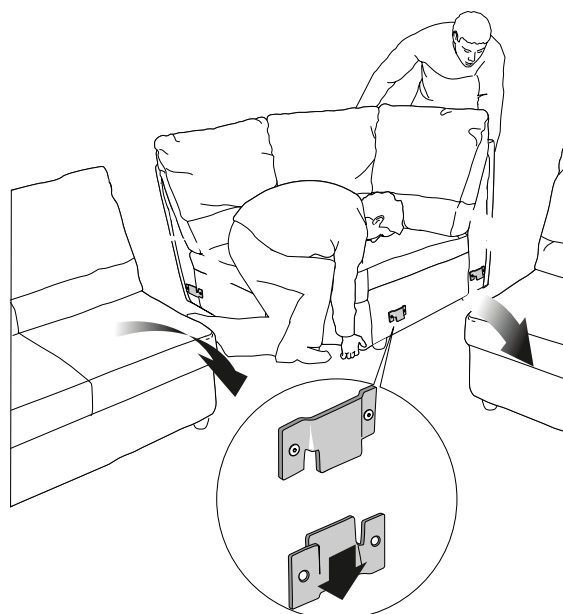
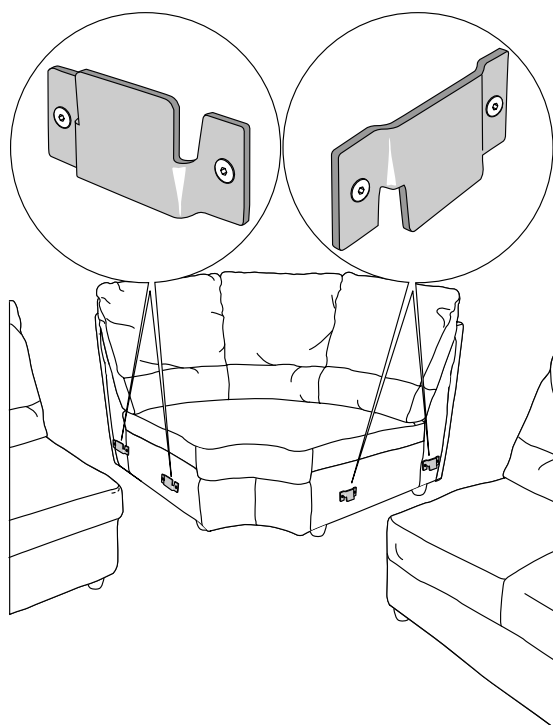
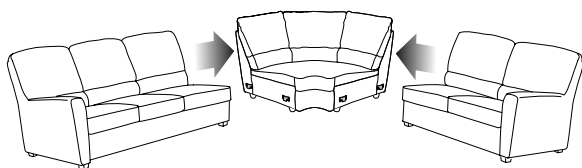

DISASSEMBLY

Lift and move the left component until it is completely detached.

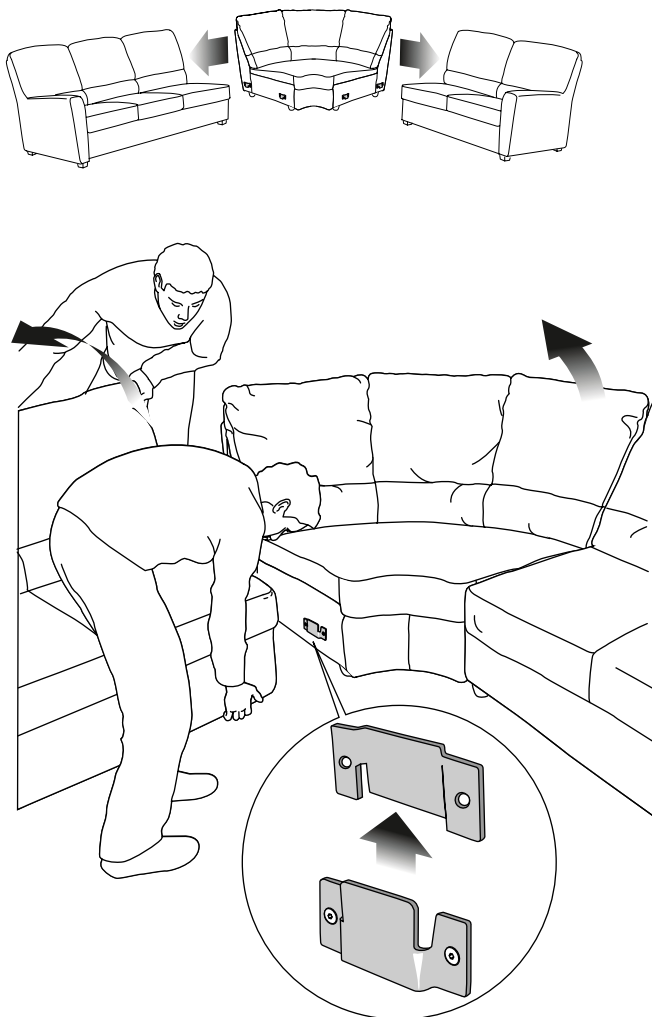

WARNING

- Do not lift and move the sofa while it is still connected.
- Do not lift the right-side component, to avoid detaching the connecting lever.
- THE LEVERS MAY BE FITTED IN A DIFFERENT WAY IN CERTAIN VERSIONS: IN THESE CASES FOLLOW THE INSTRUCTIONS DETAILED IN THE ILLUSTRATING LEAFLET ATTACHED TO THE SOFA.

10.4 INSTRUCTIONS FOR METAL BRACKET ASSEMBLY

The connecting system consists of a notched metal bracket fitted on the bottom of the right-side component, which must fit inside the metal support mounted on the left-side component.

ASSEMBLY

Rotate the notched bracket towards the outside of the component. Line up the components, taking care to insert the bracket in the hook-up elements of the left component, and tighten them until they are locked in place.

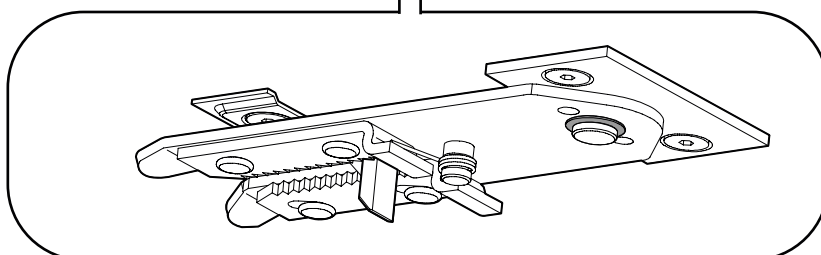
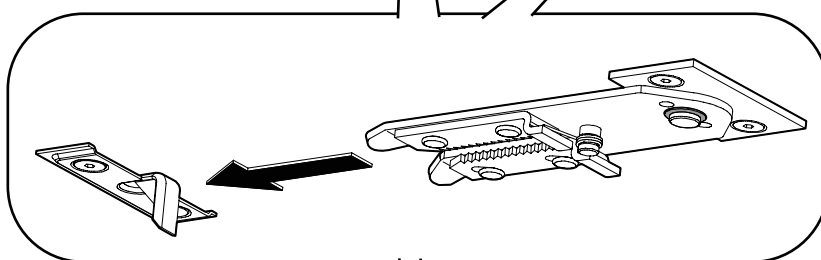
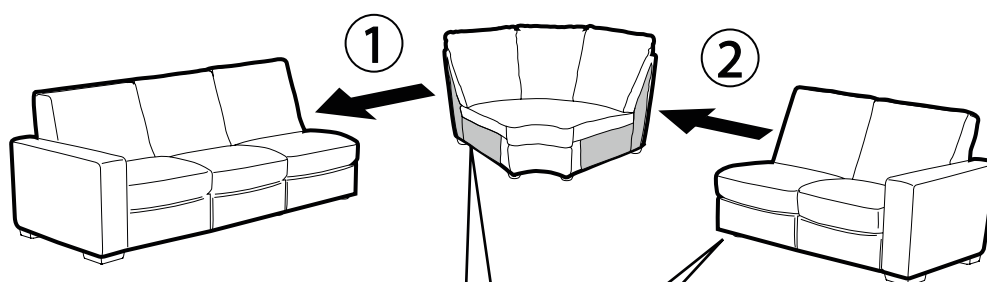
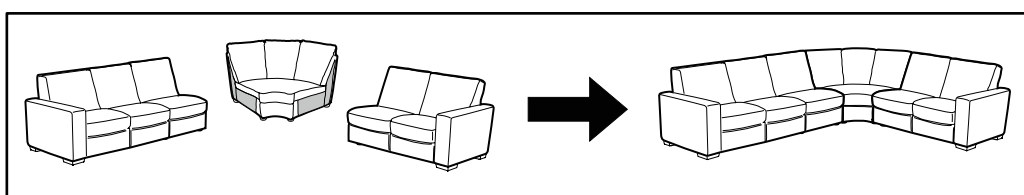

DISASSEMBLY

Lift and move the left component until it is completely detached

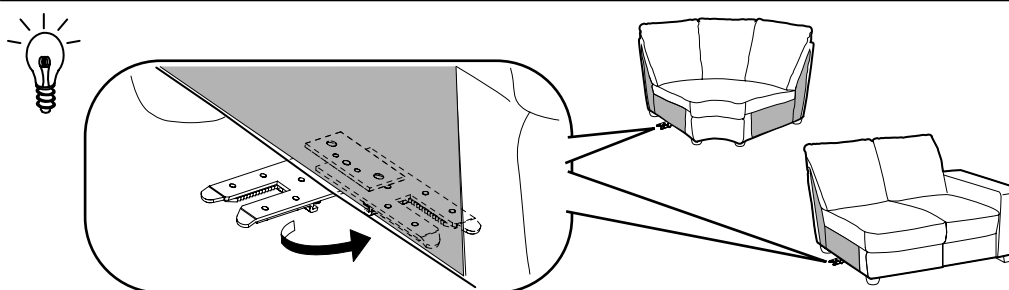
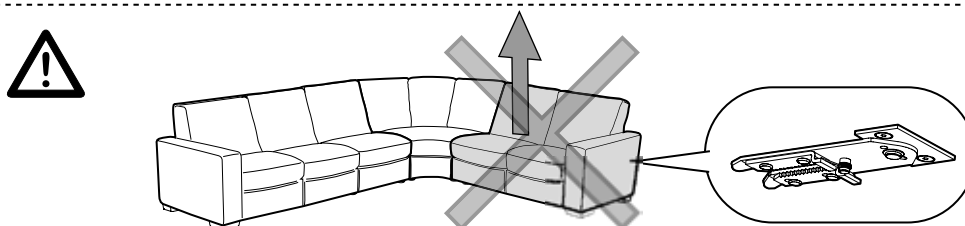
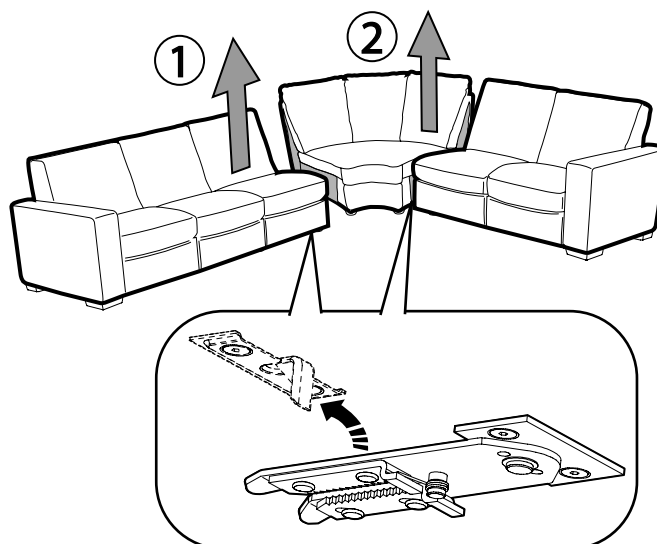
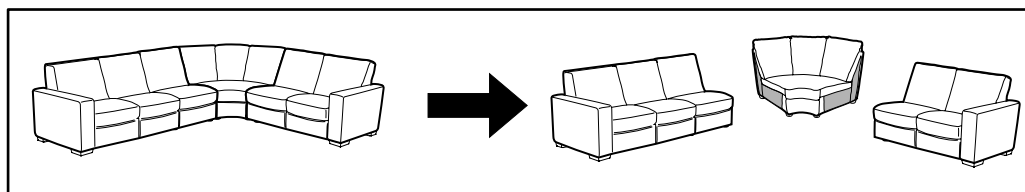

WARNING

- Do not lift and move the sofa while it is still connected.
- Do not lift the right-side component, to avoid detaching the connecting lever.
- THE LEVERS MAY BE FITTED IN A DIFFERENT WAY IN CERTAIN VERSIONS: IN THESE CASES FOLLOW THE INSTRUCTIONS DETAILED IN THE ILLUSTRATING LEAFLET ATTACHED TO THE SOFA.